

2016 Camaro SS Intercooled System **Installation Guide**



PROCHARGER[®]
SUPERCHARGER SYSTEMS

The **ULTIMATE** Power Adder™

Accessible Technologies, Inc.
14801 W. 114th Terrace
Lenexa, KS 66215
Phone: 913.338.2886
Fax: 913.338.2879
techserv@procharger.com

All rights reserved. Accessible Technologies Inc. hereby grants permission to use and reproduce this document for personal use, provided that all copyright information be retained. Reproduction of this document for unauthorized commercial use is strictly prohibited.

Information in this document is subject to change without notice.

ProCharger is a registered trademark and The Intercooled Supercharging Experts!TM and Designed to Blow Away the CompetitionTM are trademarks of Accessible Technologies, Inc. and may not be used without express permission.

You should also have the following gauges available to properly check the finished installation and monitor your vehicle's performance (especially for testing):

- Manifold Boost Pressure Gauge
- Fuel Pressure Gauge
- Wide Band Oxygen Sensor and Gauge

Gauges should be of a type that can be read from the cockpit while performing a wide-open throttle road test. Cockpit or hood-mounted gauges are preferable. In order to obtain usable readings, the gauges should measure pressure at the intake manifold and fuel rail. IF VEHICLE DOES NOT MAINTAIN PROPER FUEL PRESSURE (50-65 PSI), DECREASE THROTTLE APPLICATION IMMEDIATELY. In some cases, extra vehicle modifications can strain the stock fuel pump. If your vehicle has difficulty retaining adequate fuel pressure, contact ATI ProCharger about the availability of an upgraded fuel system.

The engine on which the ProCharger[®] is to be installed should retain the factory compression ratio. If it has been modified in any way, please consult ProCharger staff before proceeding with the installation. This supercharger system is intended for use on STOCK, strong, well-maintained engines/transmissions. Installation on a worn or troublesome powertrain should be reconsidered. ATI PROCHARGER WILL NOT BE HELD RESPONSIBLE FOR DAMAGE TO A VEHICLE'S POWERTRAIN. ATI ProCharger is not responsible for ECM tuning/programming on non-stock vehicles. ATI PROCHARGER recommends verifying that your vehicle has current ECM updates from the vehicle manufacturer before installation.

For best performance and reliability, always use premium grade fuel (91 octane or higher) and listen closely for signs of detonation, which might sound like ball bearings rolling around in a tin can. IF DETONATION SHOULD OCCUR, OR IF YOU ARE UNSURE WHETHER WHAT YOU'RE HEARING IS DETONATION, DECREASE THROTTLE APPLICATION IMMEDIATELY and please consult ATI ProCharger staff. Detonation should not be an issue with a properly installed intercooled supercharger system, though OEM factory-shipped engine and parts inconsistencies are possible on any vehicle.

INTRODUCTION

Congratulations on purchasing your ProCharger® 2016 Camaro SS Intercooled System. Read this entire manual before you attempt to install your ProCharger kit. It is imperative that you follow all of the instructions in the order they appear in this installation guide. If you have any questions regarding any aspect of this installation, call us at (913) 338-2886.

For best results, we recommend reviewing the installation instructions beforehand, and following the installation instructions closely and in sequence. A detailed packing list has been provided to assist you in identifying the components of your ProCharger system.

 **Tech Tip:** *Installing spark plugs that are one heat range colder than stock and gapping your plugs to .035" is recommended.*

 **Warning:** *Read and understand all safety precautions in this manual before installation. Failure to comply with instructions in this manual could result in personal injury, property damage, and/or voiding your warranty.*

Required Tools and Supplies

- Open End Wrench Set (standard & metric)
- 3/8" & 1/2" Socket Sets (standard & metric)
- 3/8" Hex Bit Set (standard & metric)
- 7mm & 8mm nut driver
- T15 & T45 Torx bits
- Pry Bar
- 1/2" Breaker Bar
- Flat & Phillips Screwdrivers
- Plier Set
- Hose cutter
- Silicone Gasket Maker
- 1/2" Drill Bit and Drill

 **Warning:** *Your supercharged Camaro must always be run on 91 octane or better gas. The best way to insure this is to run the tank near empty (below 1/4) and fill with 91 octane for several tanks prior to installing the supercharger.*

TABLE OF CONTENTS

Introduction i

Table of Contents.....ii

Tuning 1

Getting Started..... 2

Cooling System 11

Crank Pulley 13

ProCharger Installation 16

Intercooler and Tubing..... 19

Component Relocation 27

Surge System 32

Air Inlet 35

Final Assembly 37

Operation and Maintenance 39

Limited Warranty 41

ProCharger Extended Coverage..... 42

TUNING THESE VEHICLES IS A MULTI-STEP PROCESS THAT SHOULD BE INITIATED BEFORE SYSTEM INSTALLATION BEGINS. PLEASE ALLOW 24 HOURS TO RECEIVE YOUR MODIFIED TUNE FILE. CONTACT ATI WITH ANY QUESTIONS REGARDING TUNING FOR THESE VEHICLES.

TUNING

✓ **Note:** This section only applies to full systems, which include a handheld tuner. If you do not have a full system, additional tuning will be required before starting the vehicle.

✓ **Tech Tip:** Tuning your vehicle correctly is extremely important and is necessary for proper vehicle operation and safety. If you have any questions regarding tuning your vehicle or with any steps outlined in these instructions, call a technical service representative at (913) 338-2886.

- 1 Set the parking brake. Plug the X4 handheld into the vehicle's OBDII port. Proceed to Program Vehicle and then to Upload Stock. Follow the on-screen prompts. The device will read the stock tune from the vehicle.
- 2 Download SCT Device Updater from www.sctflash.com to your computer. Using SCT Device Updater, click on Get Stock File From Device. This will generate 2 files:
 1. " - - - ".bef
 2. "vin#" .sul
- 3 Email the 2 files to tuning@procharger.com along with the serial number from the blower and X4 handheld.
- 4 The tune for your vehicle will be emailed back to you from tuning@procharger.com. Upload the tune from your computer to the X4 handheld using the Device Updater Software.
- 5 Plug the X4 handheld into the OBDII port. Proceed to Program Vehicle, Select Custom Tune, and Select Tune following the on-screen prompts.

GETTING STARTED



Completion of this section will configure the vehicle for system installation:

- (A) Factory Air Filter Box
- (B) Mass Airflow (MAF) sensor
- (C) Factory Inlet Tube
- (D) Coolant Reservoir

! *Read and understand all safety precautions in this manual before installation. Failure to comply with instructions in this manual could result in personal injury, property damage, and/or voiding your warranty.*

- 1 Use a 22mm socket to break the lug nuts loose on the front wheels, but do not remove.
- 2 Ensure the parking brake is fully engaged. Raise the front of the vehicle. Support with jack stands.
- 3 Remove the front wheels from the vehicle.



Remove Front Wheels

- 4 Use a T15 torx to remove the (8) screws at the top of the front fascia.
- 5 Remove the (2) plastic push clips on the top of the fascia.



Remove Screws and Push Clips

- 6 Remove the plastic trim on top of the fascia by pulling up to unclip them.



Remove the Plastic Trim

Getting Started

- 7** Underneath the car, use a 7mm and 10mm to remove the (10) screws, (6) bolts, and (1) plastic push clip holding the plastic splash panel. Remove the panel.
- 8** Remove the remaining (12) screws on the bottom of the fascia.
- 9** Use a T15 torx to remove the (4) screws holding the wheel liner to the fascia and fender. Repeat for other side.
- 10** Pull the wheel liner back to gain access to fascia screws. Use a 7mm to remove the 3 screws going vertically into the fender. Repeat for other side.



Plastic Splash Panel Screws and Bolts



Remove Wheel Liner Screws



Screws Behind Wheel Liner

- 11 Use a 7mm to remove the (4) screws going horizontally into the fender. Repeat for the other side.

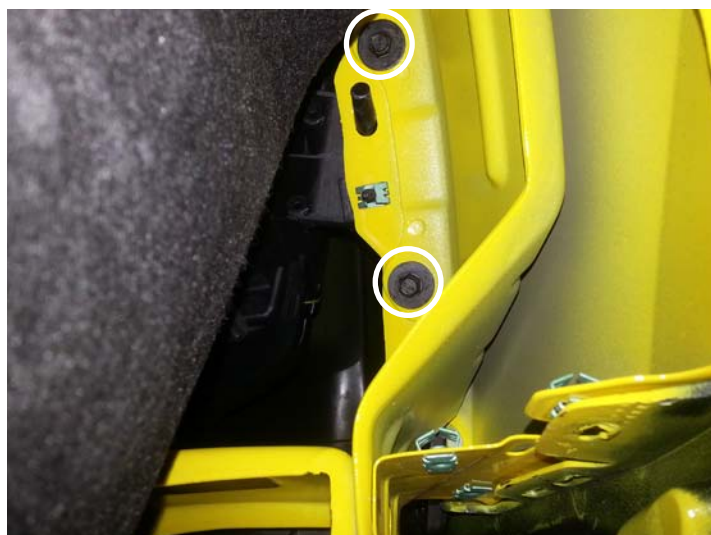

Screws Behind Wheel Liner
(Lower Two Shown)

- 12 Behind the driver's side wheel liner, locate and disconnect the fascia's wiring harness connector. Unclip the harness from the body to allow the fascia to be removed.

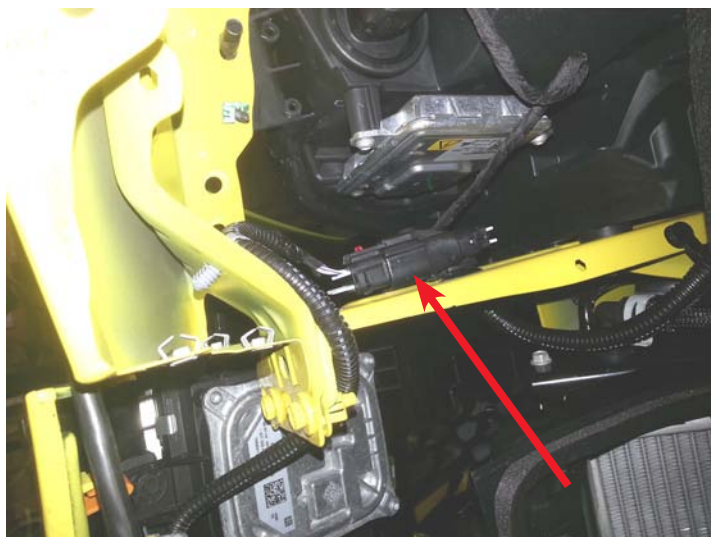

Wiring Harness Connector

Getting Started

- 13 Pull outward on the fascia where it attaches to the fenders. Pull fascia straight back to remove.



Fascia Removed

- 14 Use pliers to disconnect the sound tube hose from the air inlet tube.
- 15 Locate the PCV line that runs from the air inlet tube to the PCV reservoir near the passenger's side cylinder head. Squeeze the connectors to release them. Remove the line.



Disconnect Hoses from Inlet Tube

- 16 Disconnect the MAF (Mass Air Flow) sensor.
- 17 Use an 8mm to loosen the (2) hose clamps on the air inlet tube. Remove tube.
- 18 Disconnect air tube from air filter box. Pull up on air filter box to remove.



Air Inlet Tube Removed

- 19 Separate the air tube holders at the (2) spots near the firewall.



Disconnect Air Tube Holders

- 20 Use a 10mm to remove the nut holding the air tube to the firewall. Twist the tube clockwise and pull to disconnect from firewall.



Remove Nut on Firewall

- 21 Use a T45 torx to remove the (2) bolts holding the air tube diaphragm to the engine. Remove the air tube from the car.



Air Tube Diaphragm

Getting Started

- 22** Use a 10mm to remove the (4) bolts holding the radiator cover. Remove cover.



Remove Radiator Cover Bolts

- 23** Use a flat screw driver to remove the (3) plastic push clips that go through the transmission cooler bracket into the brake duct. Repeat for other side.



Brake Duct Push Clips

- 24** Remove the (5) plastic push clips that hold the driver's side auxiliary radiator scoop. Remove the driver's scoop.

- 25** Remove the plastic push clip that goes from the top of the brake duct vertically into the frame rail. Remove the both the driver's and passenger's side brake ducts.



Radiator Scoop Push Clips

- 26** Use a 7mm to remove the (4) screws holding the driver's side headlight. Pull headlight forward and unplug the (2) electrical connectors. Remove headlight.



Remove Headlight Screws

- 27** Use a flat screwdriver to remove the (3) plastic push clips holding the driver's side headlight shroud. Remove the shroud.



Remove Headlight Shroud Clips

- 28** Remove the (3) plastic push clips holding the plastic panel next to the passenger's side headlight. Remove the panel.



Remove Plastic Panel (Passenger's Side)

Getting Started

- 29 Use a flat screwdriver to remove additional plastic push clips holding the plastic covers on the driver's side. Remove the covers.
- 30 Use a 10mm to remove the core support braces. These will be reinstalled at a later time.



Remove Plastic Covers (Driver's Side)

- 31 Pull up on the wiring harness connector at the horn bracket stud.
- 32 Use a 10mm to remove the stud.
- 33 Unplug the horn electrical connector and set horns out of the way.



Factory Horn Location

COOLING SYSTEM

- 1 Make sure the engine coolant is not still hot. Remove the coolant reservoir cap.
- 2 Locate the coolant drain petcock on the passenger's side on the front of the radiator. Place a pan under the drain fitting. Loosen the fitting to drain the coolant.



Coolant Drain Fitting

- 3 Use a 13mm to remove the (2) bolts attaching the top of the driver's side radiator bracket to the frame.



Upper Radiator Bracket Bolts

- 4 Use a 10mm to remove the (2) bolts on the top of the driver's auxiliary radiator bracket that hold the two halves of the bracket together..



Radiator Bracket Bolts

Cooling System

- 5 Use a 13mm to remove the bolt attaching the bottom of the bracket to the k-member.
- 6 Let radiator hang down.
- 6 Once the coolant has finished draining, tighten the petcock. Place the pan under the driver's side auxiliary radiator.
- 7 Use pliers to release the hose clamps on the auxiliary radiator hoses. Disconnect the hoses from the radiator. Remove the radiator.
- 8 Remove the plastic push clip holding the shroud to the radiator.
- 9 Use a 10mm to loosen the (2) studs holding the radiator bracket to the radiator. By turning the 90° outlets on top of the radiator, the bracket can be slid off. You should be left with a bare radiator.
- 10 Use a 10mm to remove the brace under the fender support. Reinstall the loose bolt in the factory position and tighten with one of the M6 nuts and washers supplied in the radiator relocation bag.



Lower Radiator Bracket Bolt



Radiator Mounting Studs



Fender Support Brace

CRANK PULLEY

Manual Transmission

Auto trans skip to step 2

- 1 Put the car in 6th gear. Make sure the parking brake is fully engaged and the back tires are firmly on the ground.

Automatic Transmission

Manual skip to step 4

- 2 Underneath the car, locate the round metal access cover for the torque converter. Use a flat screw driver to remove the cover.



Torque Converter Access Cover

- 3 Use a pry bar or large flat screw driver to wedge between a torque converter bolt boss and the bellhousing.



Torque Converter Bolts

Crank Pulley

- 4 Use a 24mm and large breaker bar to remove the crank balancer bolt.
- 5 Separate the large radiator hose from the fan housing. Push the radiator hose down and out of the way.
- 6 Separate the small radiator hose from the fan housing. Move the hose over to the passenger's side temporarily.



Disconnect Radiator Hose From Fan

- 7 Insert the (6) 5/16" bolts and washers through the supplied crank pulley. Apply blue Loctite 242 to the bolts and thread the (6) supplied cam locks onto the threads from behind the pulley.
- 8 Use a 1/2" socket to lightly tighten the cam locks with the lobe end facing away from the center of the pulley and slightly towards an adjacent cam lock (as shown). This will provide clearance between the cam locks and the balancer webs.

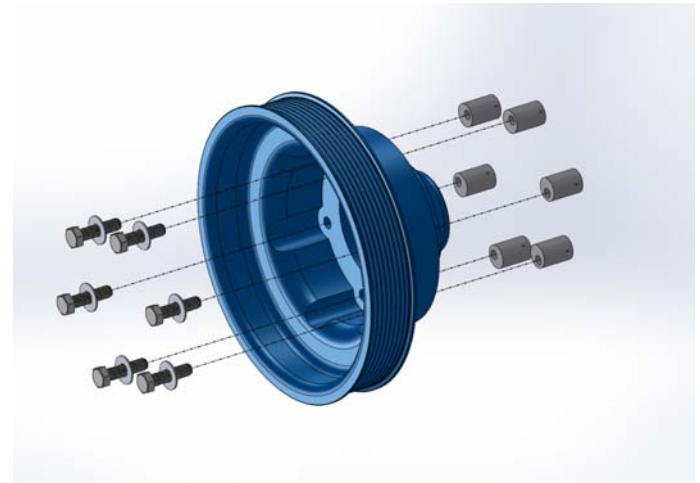

Crank Pulley and Cam Lock Assembly

- 9 Apply a bead of silicone around the crank pulley where it seats against the balancer.

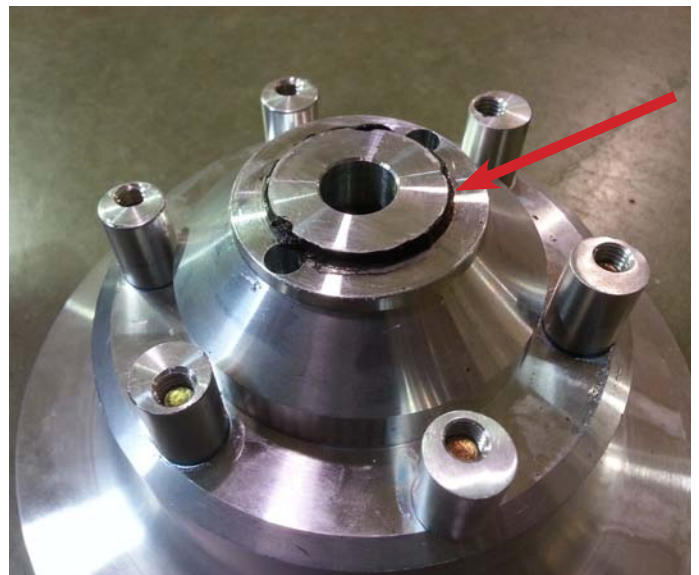

Apply a Bead of Silicone

- 10 Insert the crank pulley over the balancer. Rotate the pulley until it sits up squarely against the balancer.
- 11 Apply a bead of silicone around the supplied crankshaft bolt head and washer. Insert the bolt through the pulley into the crankshaft. Thread the bolt in until hand tight.
- 12 Back the cam lock bolts off approximately 1 turn. Rotate the crank pulley counterclockwise until the cam locks stop the pulley.
- 13 Use a 1/2" socket to tighten the cam lock bolts.
- 14 Use a 24mm to tighten the crank bolt to 240 ft-lbs.
- 15 Do not reconnect the radiator hose to its original location on the fan. Slide the plastic ring towards the passenger's side and out of the way. Use a zip tie around the fan structure and the hard plastic section of the radiator hose "T" to securely hold the radiator hose away from the crank pulley. Ensure the fan blades will not contact the zip tie.

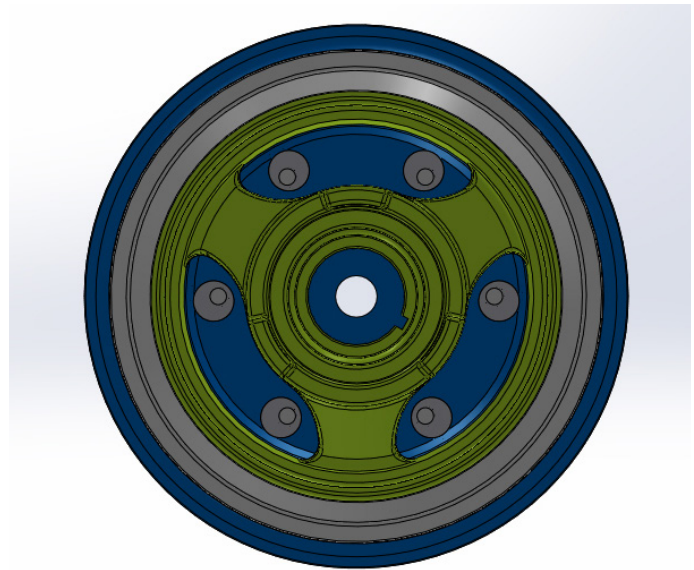

Cam Lock Assembly Direction



Zip Tie Radiator Hose to Fan

PROCHARGER INSTALLATION

1 Disconnect the wiring harness and plastic air line from the bracket holding the A/C line to the frame rail.

2 Use a 10mm to remove the nut holding the bracket to the frame rail. Slide the bracket off the A/C line.

3 Located in the radiator relocation bag, assemble the new A/C line bracket by sliding the supplied panel nut over the end of the bracket. The rubber loop clamp will be attached as shown, using the supplied M6 bolt.

4 Attach the rubber loop clamp around the A/C line. Run the supplied bolt through the loop clamp and into the panel nut on the new A/C bracket. Mount the bracket to the factory location and reinstall the factory nut.



Factory A/C Line Bracket



Assembled A/C Line Bracket



Factory A/C Line Bracket

- 5 Locate the bracket bag. Use a 3/4" wrench to remove the idler pulley.
- 6 Use a 13mm to loosen the connector bracket on the cylinder head. Remove the wiring harness attachment at the head.
- 7 Assemble the main bracket as shown. Note that the (3) spacers are all the same length, but (1) has a smaller inside diameter for the smaller diameter 8mm bolt. The 8mm bolt goes in the uppermost mounting hole. Mount the bracket to the engine. Tighten the bolts using 17mm and 13mm sockets. Retighten the electrical connector bracket.
- 8 Reinstall the idler pulley into the lower threaded hole. Tighten with a 3/4" wrench.

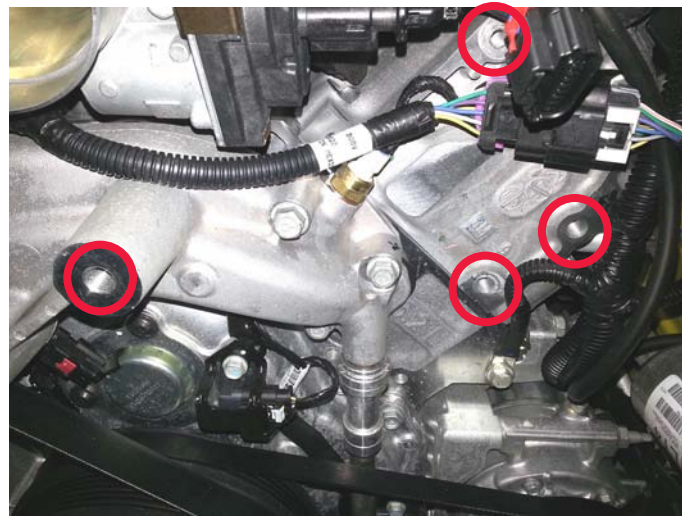

Bracket Mounting Holes

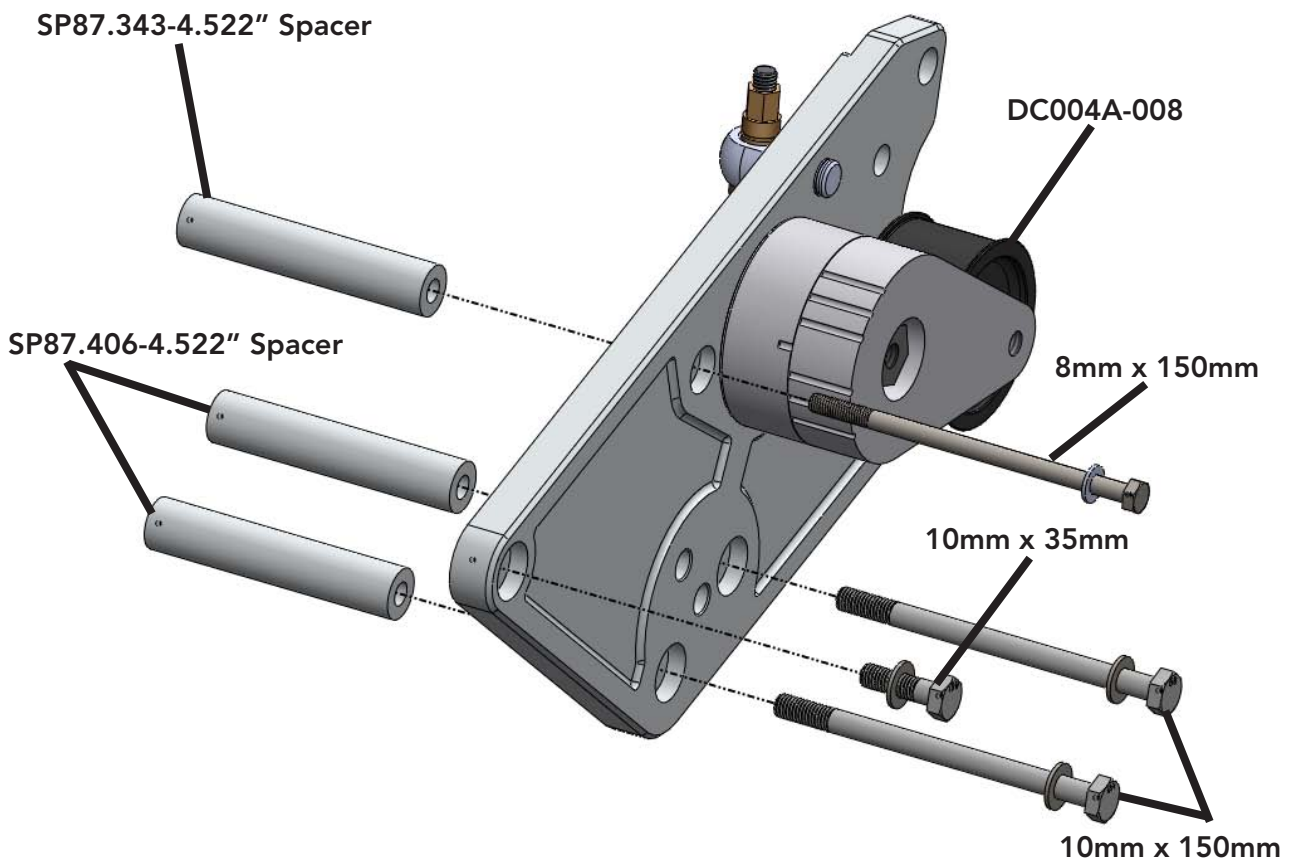

Main Bracket Assembly

ProCharger Installation

- 9 Install the 90° fitting onto the bottom of the supercharger's drain fitting. Install the oil drain line onto the 90° fitting. Fill the supercharger with the supplied blower oil.
- 10 Mount the ProCharger onto the main bracket using the provided 5/16" and 3/8" SHCS's. Tighten the fasteners using 1/4" and 5/16" allen keys.



Supercharger Mounted

- ✓ **Tech Tip:** The tensioner will have to be moved up and down to gain clearance for the supercharger bolts. This can be done by turning the brass tensioner collar with a 1/2" socket.

- 11 Use a 3/4" to loosen the tensioner pivot bolt. Use a 9/16" to loosen the jackscrew mounting bolt just enough for the tensioner to pivot. Using a 1/2", turn the brass collar clockwise to rotate the tensioner all the way up.

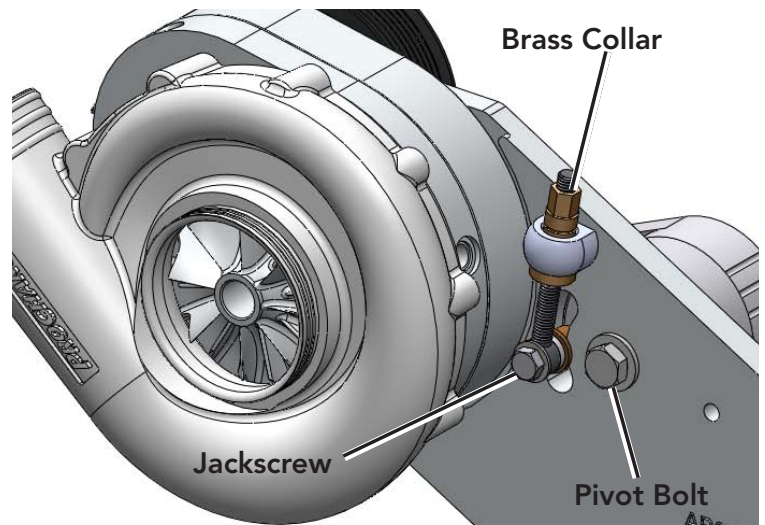

Tensioner Assembly

- 12 Install the supplied supercharger belt.

- 13 Tighten the belt by rotating the brass collar counterclockwise until the first set of etched marks on the tensioner body align. Use a 3/4" to tighten the pivot bolt. Ensure the bolt is tight enough to hold the tensioner from rotating. Turn the brass collar clockwise to release tension on the jackscrew. Use a 9/16" to tighten the jackscrew mounting bolt.

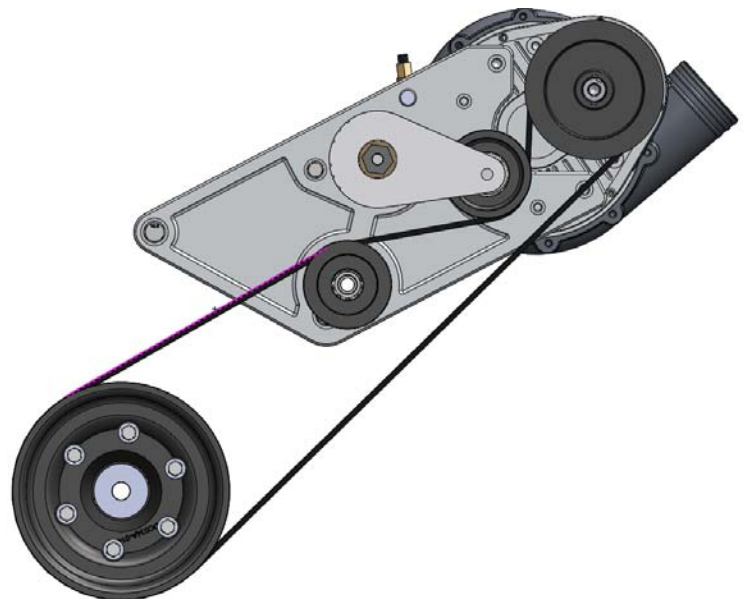

Belt Routing

INTERCOOLER AND TUBING

- 1 Use a 10mm to remove the (2) bolts that hold the transmission cooler bracket to the bottom side of the bumper.
- 2 Underneath the transmission cooler, unclip the transmission line from the plastic air shroud.
- 3 Remove the ambient air temperature sensor from the passenger's side of the shroud.
- 4 Remove the air shroud.
- 5 Rotate the transmission cooler down and let hang.



Transmission Bracket Bolt



Ambient Air Temperature Sensor



Transmission Cooler Dropped Down

Intercooler and Tubing

- 6 Use a flat screwdriver to remove the plastic push clip on the bottom of the driver's side radiator/condensor plastic cover.
- 7 Use a flat screwdriver to remove the (4) metal lock tabs on the cover.
- 8 The cover surrounds the A/C lines. Cut the cover just above the upper A/C line connection to remove the cover from the vehicle.
- 9 Repeat these steps to remove the passenger's side plastic cover.

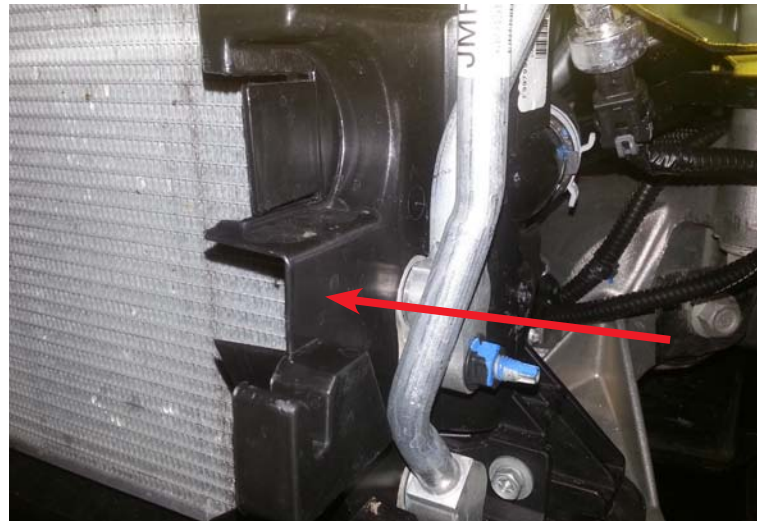

Plastic Radiator Cover (Driver's)



Plastic Radiator Cover (Passenger's)

- 10 Use a 10mm to remove the (2) nuts holding the driver's side transmission cooler bracket to the cooler.
- 11 Install the supplied modified transmission cooler bracket. Let the cooler hang down.



Plastic Radiator Cover (Passenger's)

- 12 Disconnect the plastic push clip from the passenger's side radiator duct going into the bumper. Disconnect all of the wiring harness connections to the bumper.
- 13 Use a 13mm to remove the (8) bumper to frame bolts to remove the bumper.



Bumper to Frame Bolts

- 14 Place the intercooler brackets between the frame rails and the bumper, oriented as shown.

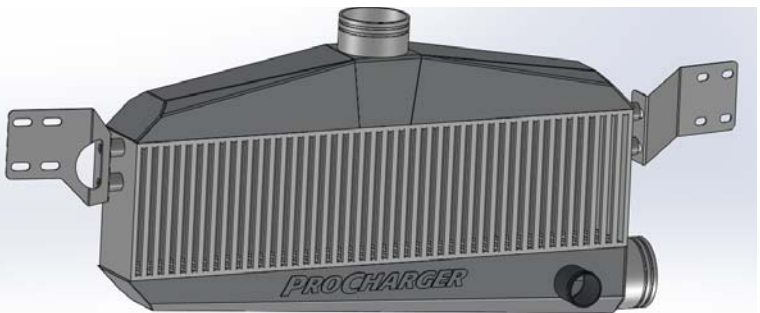

Intercooler Bracket Orientation

- 15 Reinstall the bumper, but leave the bolts loose to allow the intercooler brackets to slide for adjustment.

- 16 Slide the intercooler up between the bumper and the radiator.

- 17 Start the (4) supplied 3/8" bolts and washers through the brackets and into the bungs on the intercooler. Leave loose.

- 18 Adjust the intercooler forward and make sure the inlet to the intercooler on the bottom clears the a/c line.

- 19 Use a 9/16" to tighten the intercooler bracket bolts. Use a 13mm to tighten the bumper bolts.



Intercooler Mounted

- ✓ **Tech Tip:** Align the bumper how it was from the factory by matching up the washers with the unpainted sections on the bumper.

H.O. INTERCOOLER AND TUBE ROUTING

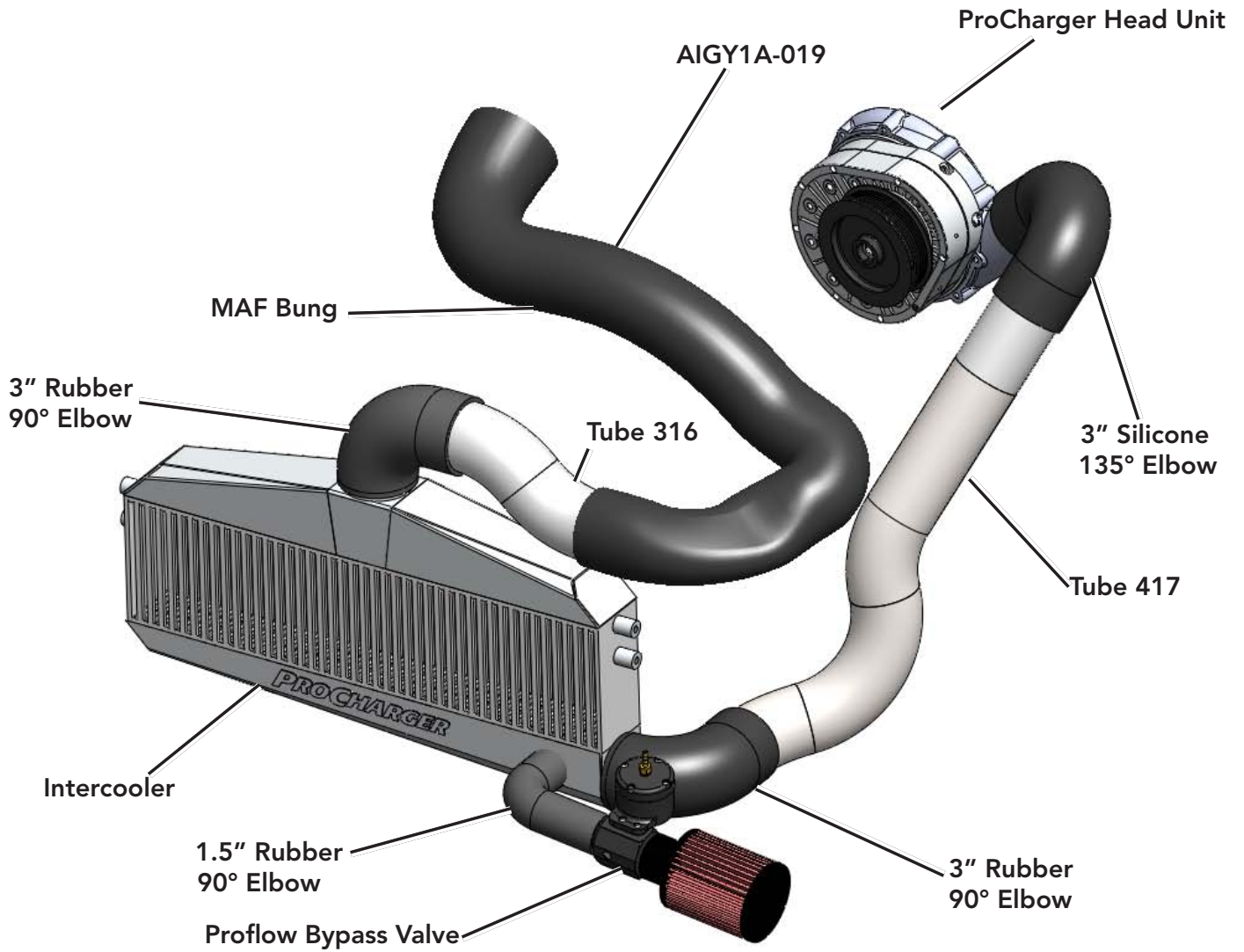

STAGE 2 INTERCOOLER AND TUBE ROUTING

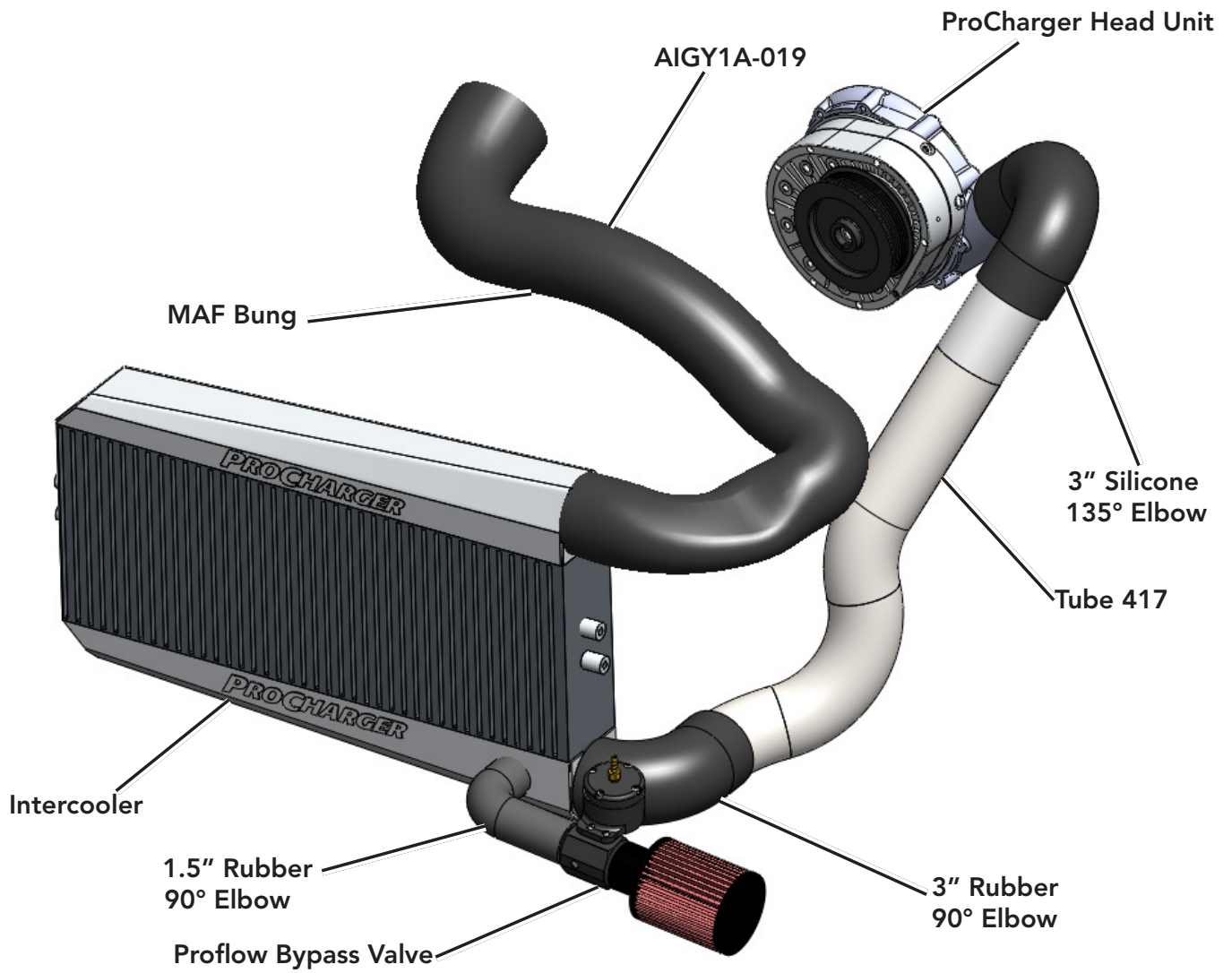

Intercooler and Tubing

✓ **Tech Tip:** Leave all hose clamps loose to allow for adjustment. Tighten after all tubes are in place.

- 21 Insert the 135° silicone elbow over the outlet of the supercharger. Secure with the supplied 3.38" T-bolt clamp.
- 22 Slide tube #417 into the open end of the silicone elbow. Secure with the supplied 3.25" T-bolt clamp.



Blower Discharge Tube Installed

- 23 Slide the longer leg of one of the 90° rubber elbows over the open end of tube #417. Secure with a #52 hose clamp.
- 24 Slide the short end of the elbow over the lower intercooler outlet. Secure with a #52 hose clamp.



Lower Intercooler Connection

- 25 Use a T15 torx to remove the (2) screws holding the MAF sensor to the factory air box.
- 26 Use a 7mm to install the MAF sensor into the bung molded into the silicone hose using the supplied M4 screws and washers.



Remove MAF Sensor from Factory Air Box

H.O. Intercooler ONLY

Stage 2 Intercooler Skip Next 2

- 27 Slide the short leg of the other 90° rubber elbow over the top outlet on the intercooler. Secure with a #52 hose clamp.
- 28 Insert tube #316 into the open end of the elbow. Secure with a #52 hose clamp.



Tube #316 Installed (H.O. Intercooler Only)

H.O. & Stage 2

- 29** *H.O. intercooler* - Slide the 3" end of the molded silicone hose over the open end of tube #316.
Stage 2 intercooler - Slide the 3" end of the molded silicone hose over the top outlet of the intercooler.
Secure with a #52 hose clamp.



Molded Silicone Hose Installed (Stage 2 Shown)

- 30** Connect the molded silicone hose to the throttle body. Secure with a 4.25" T-bolt clamp.



Throttle Body Connection

COMPONENT RELOCATION

- 1 Reinstall the core support to bumper brackets. Leave the lower bolt on the passenger's side out temporarily.
- 2 Use a 10mm to remove the (2) nuts holding the horns to the bracket. Flip the horns side to side on the bracket and reinstall the nuts, but leave loose.
- 3 Slide the horn bracket between the core support brace and the bumper. Reinstall the bolt through the brace and horn bracket into the bumper. Leave loose.
- 4 Disconnect any wiring harness push pins that hold the wiring harness to allow it to move towards the passenger's side.
- 5 Reconnect the horn electrical connector.
- 6 Adjust the horns so they point toward the rear of the car. Use a 10mm to tighten the horn nuts. Use a 10mm to tighten the brace and bracket bolt.
- 7 Locate the brake assist pump. Disconnect the (2) vacuum lines and (1) electrical connector from the pump.
- 8 Use a 13mm to remove the (2) pump bracket bolts holding it to the frame rail. Remove the pump and bracket.
- 9 Use a 10mm to remove the bracket from the pump.



Horns Relocated



Brake Assist Pump

Component Relocation

- 10 Mount the supplied brake pump bracket to the pump using the factory hardware.

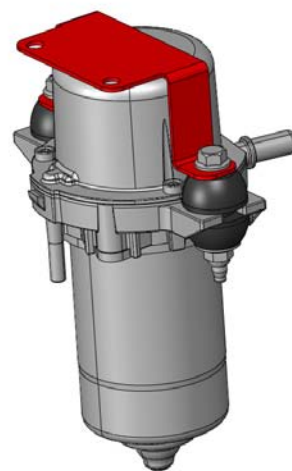

Brake Pump Bracket

- 11 Slide the supplied M6 panel nuts onto the brake pump bracket with the threaded portion pointing down towards the pump.

- 12 Mount the upper radiator bracket to the brake pump bracket using the (2) supplied M6 bolts and washers.

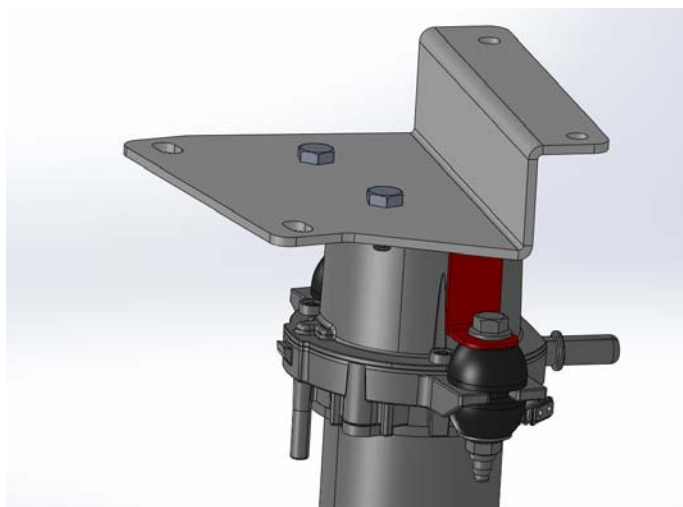

Brake Pump to Radiator Bracket

- 13 Place the bracket assembly over the exposed studs from the bracing that goes under the driver's headlight. Use the supplied M6 washers and nuts to secure the bracket using a 10mm.



Upper Bracket Mounting Studs (Underneath)

- 14 Reconnect the electrical connector and the (2) vacuum lines to the brake pump.



Brake Pump Vacuum Line Reconnected

- 15 Use a phillips screw driver and supplied #14 screws to mount the radiator to the bracket.

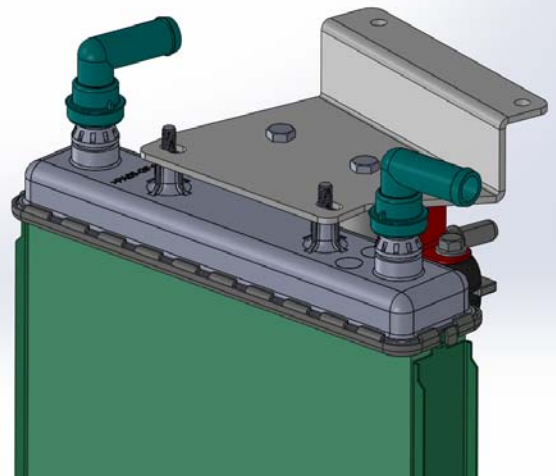

Radiator Mounted to Bracket

- 16 Remove the orange rubber grommets from the factory lower radiator bracket. Insert them into the new lower radiator bracket.



Factory Lower Bracket Grommets

Component Relocation

- 17 Slide the bracket over the pins on the bottom of the radiator. Use a 10mm to mount the bracket to the k-member using the supplied M8 bolts and washers.

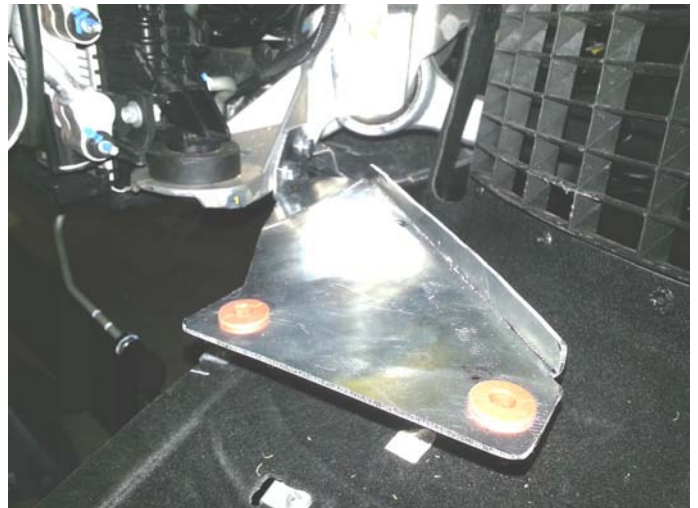

New Lower Bracket Mounting Location

- 18 Locate the factory 5/8 radiator hose that connects to the "T" in the large radiator hose in front of the crank pulley. Connect this hose to the auxiliary radiator nipple closest to the frame rail. Secure using the factory clamp.

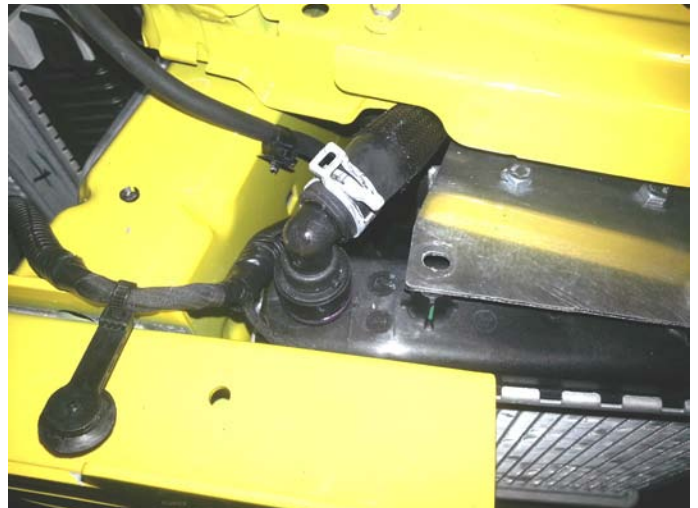

Factory Radiator Hose Connected

- 19 Locate the supplied 5/8 rubber hose. Place the short leg of the hose over the remaining nipple on the auxiliary radiator. Secure with a #8 hose clamp. Route the hose over the fender brace as shown, and along the brace towards the frame rail.



New Radiator Hose Routed

- 20 Keeping the new 5/8 hose tucked tightly to the brace and frame rail, connect the hose to the factory 5/8 hose using the supplied 5/8x5/8 brass union. Secure with the factory clamp and a #8 hose clamp. Use zip ties to retain the hoses.

✓ **Tech Tip:** Removing the throttle body tube will give better access to these hoses.



New Hose Connected to Factory Hose

- 21 Reinstall the headlight. Plug in the (2) electrical connectors.

- 22 Refill the cooling system through the coolant cap on the passenger's side. Pour the coolant in slowly to help air from being trapped in the system. Check for leaks.

✓ **Tech Tip:** Use a vacuum pump on the coolant reservoir to aid in evacuating air from the cooling system.



Cooling System Refilled

SURGE SYSTEM

- 1 If equipped with a race valve option, insert the o-ring into the groove on the intercooler flange and mount the race valve to the flange using the supplied (6) #10-24 socket head screws.



Race Valve Installed

- 2 Install the supplied modified air shroud to the transmission cooler brackets. Use a 10mm to remount the trans cooler and air shroud to the frame with the factory hardware. Reconnect the ambient air temperature sensor to its factory location.



Modified Air Shroud Installed

- 2 Reinstall the passenger's brake cooling duct. Use the factory plastic push clips through the air shroud into the cooler brackets.
- 3 Install the supplied 1-1/2" rubber hose onto the bung on the intercooler. Secure with a #24 hose clamp.
- 4 Cut the hose to the appropriate length. Insert the ProFlow surge valve into the hose. Secure with a #24 hose clamp.
- 5 Slide the filter over the surge valve and secure with a #24 hose clamp.



Proflow Surge Valve Installed

- 6 Remove the short factory PCV hose behind the throttle body on the driver's side.



Factory Vent Hose

✓ **Tech Tip:** When installing a race valve, the assembly utilizes push lock fittings and nylon hose, replacing the standard barb fitting and rubber hose. Thread the push lock fitting onto the vacuum manifold and race valve, and simply push the nylon line into each fitting to create a secure connection.

- 7 Assemble the vacuum manifold with a straight 3/8" barb fitting on one end and a 90 degree 3/8" barb fitting on the other end of the manifold. Plug (2) of the 1/8" ports with the 1/8" brass plugs. Install the 1/8" barb fitting in the remaining 1/8" port.



Vacuum Manifold Assembled

- 8 Connect the 2" long section of 3/8" rubber hose to the valley vent port. Insert the check valve into the other end of the hose, with the arrow on the check valve pointing AWAY from the valley.

- 9 Connect the 5.5" long section of 3/8" hose to other end of the check valve. Attach the 90° barb fitting into the open end of the hose. Connect the straight barb fitting to the port on the intake manifold with the 2.75" long section of hose. Secure all connections with #6 hose clamps.



Vacuum Manifold Installed

Surge System

- 10 Route the supplied vacuum line from the 1/8" barb on the vacuum manifold down to the barb fitting on the Proflow valve.

- 11 If equipped with a race valve option, install the 90° pushlock fitting on the race valve and the straight pushlock fitting on the vacuum block. Connect the fittings with the supplied nylon pushlock hose.



Vacuum Line Connected at Surge Valve

AIR INLET

- 1 Install the supplied rubber plug into the hole in the firewall where the factory air tube was removed.



Firewall Plug Installed

- 2 Use a 1/2" drill bit to drill a hole in the end of the air filter. Insert the 1/2" end of the supplied plastic hose barb into the air filter hole.



Plastic Fitting Installed in Air Filter

- 3 Slide the air filter over the rotomold inlet tube.
- 4 Slide the tube over the inlet of the supercharger. Adjust the tube and the air filter and secure with the supplied hose clamps.



Air Inlet Installed

Air Inlet

- 5 Insert the short leg of the supplied 5/8" rubber hose over the open port on the PCV reservoir. Cut the hose to fit properly over the port. Secure with a #10 hose clamp.



PCV Reservoir Hose

- 6 Route the hose around the back of the engine and connect it to the plastic fitting on the air filter. Secure the line with zip ties.



PCV Hose Routed

FINAL ASSEMBLY

- 1 Locate the air duct on the back side of the fascia on the driver's side.
- 2 Use a 7mm to remove the (3) screws holding the fog light assembly to the fascia.
- 3 Unclip the (3) wiring harness push clips from the air duct.
- 4 Remove the metal lock clip in the lower corner.
- 5 Release the (2) plastic latches and remove the air duct.
- 6 Reinstall the fog light assembly.
- 6 Reinstall the radiator cover.
- 7 Reinstall the front fascia.
- 8 From under the car, ensure the surge valve linkage is unobstructed. Use zip ties to retain the surge valve so it does not damage the radiator.



Fog Light Removed



Surge Valve After Fascia Installation

- 9 Connect the MAF sensor to the factory connector using the supplied MAF extension harness.
- 10 Route the harness away from any moving parts. Use zip ties to secure
- 11 Start the engine. Check for leaks. After reaching operating temperature, shut the engine off and allow to cool down. Fill coolant as needed.



Tech Tip: It is highly recommended that colder heat range spark plugs are installed. NGK 6510 spark plugs are recommended for most applications.



CONGRATULATIONS! YOU HAVE COMPLETED THE INSTALLATION OF YOUR NEW PROCHARGER SUPERCHARGER SYSTEM. READ THE FOLLOWING PAGES CAREFULLY FOR OPERATION AND MAINTENANCE INSTRUCTIONS, AS WELL AS WARRANTY INFORMATION.

OPERATION AND MAINTENANCE

Cold Starting

Never race your engine and ProCharger supercharger when your engine is cold. Allow the water temperature to climb into operating range for several minutes before driving above 2,500 rpm, to ensure adequate oil lubrication.

Fuel Quality

With a properly installed intercooled ProCharger supercharger system, detonation should not occur. For the best performance and reliability, use premium grade fuel (91 octane or higher). Listen for signs of detonation after refueling, and after replacement or modification of any fuel system component(s). If detonation occurs, reduce the throttle and locate the source.

Ignition System Maintenance

If your spark plugs are more than a year old or have more than 10,000 miles logged, you should consider changing them before driving your vehicle under load. Spark plug wires should be changed if visibly damaged or when resistance exceeds factory specifications.

Air Filter Maintenance

Your air filters should be cleaned periodically, potentially as often as every 10,000 miles or 6 months, even though a service interval of 50,000 - 100,000 miles is quoted by the manufacturer under normal driving conditions. A clogged air filter will result in decreased boost levels and vehicle performance. Be sure to re-oil the cleaned filter before re-installing. Always operate your vehicle with an air filter; failure to do so may result in damage to your ProCharger supercharger and personal injury!

Belt Replacement

The serpentine belt, which turns your ProCharger supercharger, will stretch after initial run-in, and should be retightened after the first hundred miles. Tighten the belt sufficiently to avoid slippage, but do not overtighten. Overtightening the belt could cause damage to the ProCharger supercharger's precision bearings. When re-installing the belt, use the belt routing diagram in this manual. If you reuse a thrown belt and find that it needs frequent re-tightening, the belt is damaged and should be replaced. Gates Micro-V belts can be bought from ATI or from your local parts store.

ProCharger Oil Change Intervals

The first oil change should be performed at 500 miles and at 6,000 mile intervals thereafter. Clean the drain plug after every oil change. Drain oil by removing the drain plug. Clean off the drain plug before re-installing.

ProCharger Oil Level

The ProCharger supercharger's oil level must be checked periodically to ensure the proper lubrication. The dipstick can be loosened using a flat blade screwdriver or a coin. When installed, the oil level should remain between the minimum (MIN) and maximum (MAX) indicators at all times.

! **Warning:** Filling the ProCharger higher than the maximum level on the dipstick can lead to bearing and seal damage. The supercharger is a sealed unit and should not normally require the addition of oil between service intervals. If excessive usage is noted, the unit should be sent to ATI for inspection and repair. The dipstick fitting should be firmly tightened after changing or checking the oil level.

General

When removing the dipstick, be sure to retain the nylon washer. A spare nylon washer and o-ring is included. Use only the ATI supplied nylon washer and o-ring when servicing the oil dipstick and drain plug. A discoloration of the oil and residue on the drain plug may occur during the initial oil changes. This is normal and will gradually decrease. For the proper positioning of the ProCharger supercharger, the serial tag should be pointing upwards. Installing the ProCharger supercharger in another position will cause inadequate oiling and supercharger failure. If you have any questions about the maintenance of your supercharger, contact ATI.

! **Warning:** The supercharger contains no oil from the factory. The unit must be filled prior to use. Use only ATI supplied oil in your ProCharger. The ATI oil has been specially formulated for the bearings in the ProCharger and use of oil other than that supplied by ATI will void your warranty.

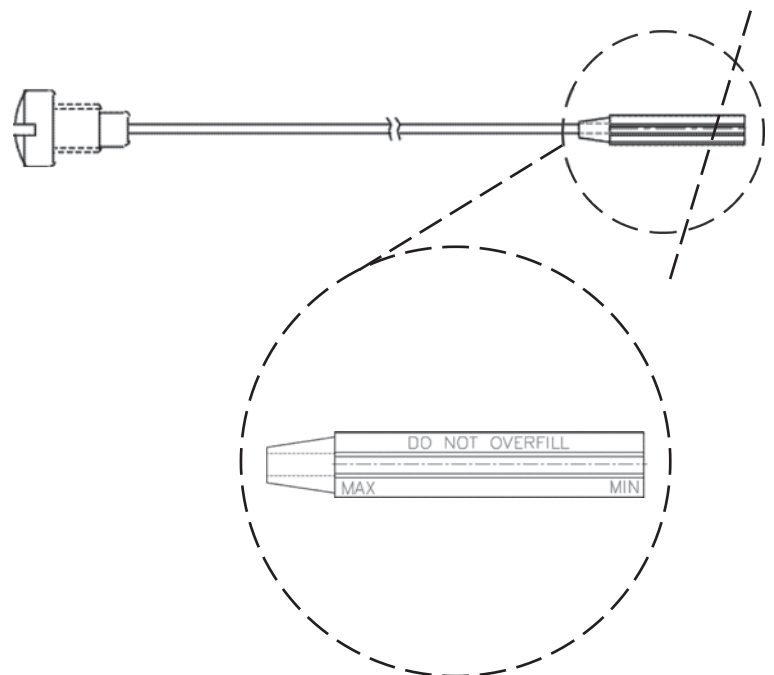
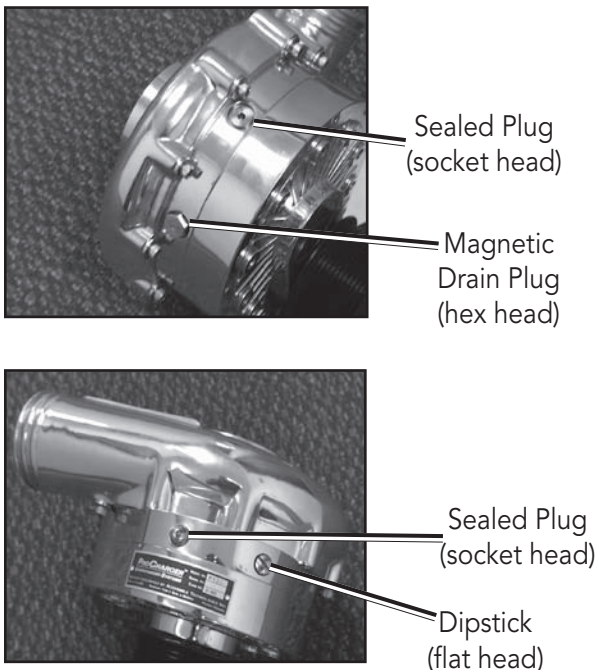

LIMITED WARRANTY

Accessible Technologies, Inc. (ATI) provides a limited twelve (12) month warranty on the ProCharger supercharger against defects in materials and workmanship unless otherwise specified. This limited warranty starts on the date of original purchase from your local dealer, or date of shipment from the factory. This limited warranty coverage is extended only to the original owner and excludes hoses, sleeves, and electronic components manufactured by other companies. IF THE SUPERCHARGER'S DRIVE RATIO IS ALTERED IN ANY WAY FROM THE FACTORY SETTING, WARRANTY COVERAGE IS VOID. USE OF ANY PULLEY NOT MANUFACTURED OR SUPPLIED BY ATI VOIDS ALL WARRANTY COVERAGE. ATI's warranty obligations are limited to the terms below:

ATI agrees to honor a warranty claim at its sole discretion and only after inspection at the ATI factory. No warranty will be honored if any part of the product is found to have been improperly installed, tampered with, mishandled, or misused in any way. Disassembly of the ProCharger supercharger or removal of the ProCharger supercharger's serial plate voids all warranties. Claims for freight damages should be directed to the freight company.

If ATI's limited warranty applies, your product will be repaired or replaced at ATI's discretion and shipped back. If the limited warranty does not apply, ATI will advise you of the specific reason, cost of the repair, and delivery time. After advising you of this information we will, at your option, either proceed with repairs or return your product to you in the state in which it was received. In either case the product will be shipped to you, insured at replacement value. Therefore, you will pay the return shipping and insurance charges if ATI's limited warranty does not apply to your product.

THE WARRANTY AND REMEDIES SET FORTH ABOVE ARE EXCLUSIVE AND IN LIEU OF ALL OTHERS, ORAL OR WRITTEN, EXPRESS OR IMPLIED. THE DURATION OF ANY AND ALL WARRANTIES ON THE PRODUCTS DISCUSSED ARE LIMITED TO THE PERIOD IDENTIFIED ABOVE. ATI IS NOT RESPONSIBLE IN ANY EVENT FOR DIRECT, SPECIAL, INCIDENTAL OR CONSEQUENTIAL DAMAGES. No ATI dealer, agent, or employee is authorized to make any modification, extension, or addition to this warranty.

To obtain service under this warranty you must do the following during the warranty period:

Phone ATI (913-338-2886) and provide us with the following information:

- ProCharger supercharger serial number.
- Vehicle year, make, model, engine modifications, and other modifications.
- Description of perceived issue.

If a solution to your issue can not be found after the above phone consultation, you will be assigned a return authorization number (RMA). You must then properly package and ship your product, at your expense, to the ATI factory. The product should be carefully packaged in a rugged box.

Include the following information inside the box with your product:

- Copy of your original invoice or receipt.
- Name, address, and daytime telephone number.
- Return authorization number (RMA).
- Vehicle year, make, model, engine modifications, and other modifications.
- Description of perceived issue.

Clearly mark the warranty claim number on the top and one side of the box in characters at least 2" tall. Properly package the product and ship it, prepaid and insured for the retail value of the component(s) being returned, to the following address:

**Accessible Technologies, 14801 West 114th Terrace,
Lenexa, Kansas 66215**

PROCHARGER EXTENDED COVERAGE

The ProCharger Extended Coverage Program extends the ProCharger warranty coverage for an additional twenty-four (24) months, for a total of thirty-six (36) months or three years of coverage. This extended coverage applies to parts for the ProCharger supercharger head unit only and does not include other system components. With your extended coverage registration, you will receive two (2) additional boxes of ProCharger Supercharger oil.

Under the extended coverage program, Accessible Technologies, Inc. (ATI) will repair or replace any component within the supercharger head unit which is found to be defective. Only the supercharger head unit itself is included in the extended coverage.

Service under the extended coverage program is obtained through the same process as described in the Limited Warranty.

Race kits are not eligible for the ProCharger Extended Coverage Plan

To qualify for the ProCharger Extended Coverage:

- Only the original owner of the ProCharger supercharger is eligible.
- Completion of the Extended Coverage Registration Form is required, along with a \$49 registration fee. This form must be completed in its entirety, and must be submitted along with payment within 30 days from the date of original purchase from your local dealer or date of shipment from the factory.
- Participants must have a ProCharger P-1SC, P-1SC-1, C1, or C2 supercharger head unit using the maximum warranted boost level. All terms and conditions within "The Limited Warranty" apply. Acts resulting in disqualification include but are not limited to the following:
 - Disassembly or modification the ProCharger supercharger.
 - Removal or attempted removal of the ProCharger drive pulley(s).
 - Removal or attempted removal of the ProCharger supercharger serial number plate.
 - Removal or attempted removal of the compressor housing or transmission case.
- Participants agree to properly maintain the ProCharger supercharger and provide proof of compliance with the following recommended maintenance:
 - Change the ProCharger supercharger oil after the initial break-in period of 500 miles (automotive) or 15 hours (marine).
 - Change the ProCharger supercharger oil every 6,000 miles after the initial break-in period.
 - Use only the specified amount of ProCharger Supercharger oil in the ProCharger supercharger.
 - Inspect and clean the magnetic drain plug at every ProCharger supercharger oil change.
 - Check the ProCharger supercharger oil level frequently.

ProCharger Extended Coverage Program Registration Form

Return this completed form and a \$49 check within 30 days of original purchase.

Name: _____

Date of Purchase: _____

Address: _____

Purchased From: _____

City: _____

ProCharger Serial #: _____

State: _____ Zip: _____

Vehicle Year: _____

Country: _____

Vehicle Make: _____

Daytime phone: _____

Vehicle Model: _____

Evening phone: _____

Please rank in order of importance starting with 1 being most important.

E-mail: _____

Age 18 - 24 25 - 34 35 - 44
 45 - 54 55 and up

Income \$15,000 - \$29,000 \$30,000 - \$44,000
 \$45,000 - \$69,000 \$70,000 and up

Which information sources most influenced your decision to purchase a ProCharger system?

- ___ Magazine advertising
- ___ Dealer recommendation
- ___ ProCharger Brochures
- ___ Witnessed performance on a car
- ___ Test drive
- ___ Magazine editorials
- ___ Friends
- ___ Conversations with ATI technicians
- ___ Web Site (please specify) _____
- ___ Other (please specify) _____

What magazines do you read?

- Car & Driver
- Car Craft
- Chevy High Performance
- Four Wheel and Off Road
- Hot Rod
- Motor Trend
- Muscle Mustangs and Fast Fords
- GM High-Tech Performance
- 5.0 Mustang
- Super Street
- Mustang Monthly
- Truck Trends
- Popular Hot Rodding
- Road & Track
- Super Chevy
- Truckin'
- Street Truck

What most influenced your decision to purchase a ProCharger system?

- ___ Reliability
- ___ Standard warranty
- ___ Extended coverage warranty
- ___ Performance
- ___ Quiet operation
- ___ Removability (ability to return car to stock)
- ___ Cost
- ___ Ease of Installation

Who installed your ProCharger system? Self Dealer Other _____

Have you own a forced induction system previously? Yes No

If yes:

Supercharger: Brand(s) _____ Vehicle(s) _____

Turbocharger: Brand(s) _____ Vehicle(s) _____

I have read and understand the policy for the ProCharger Extended Coverage Program. I have not and will not modify my ProCharger supercharger in any way during my participation in the extended coverage program. I have read and answered all questions on this form. I have enclosed my check for \$49, payable to ATI, for enrolling my ProCharger supercharger (serial number indicated above) in the extended coverage program for an additional twenty-four (24) months beyond the standard limited warranty period of twelve (12) months.

Signature _____ Date _____

Mail this completed registration form with a \$49 check to ATI at: 14801 West 114th Terrace, Lenexa, KS 66215. If you have any questions, contact us at techserv@procharger.com or (913) 338-2886 8:30 AM - 5:30 PM CST, Monday - Friday.

cut along the dotted line

cut along the dotted line

This Page is Intentionally Left Blank

This Page is Intentionally Left Blank



**Accessible Technologies, Inc.
14801 W. 114th Terrace
Lenexa, KS 66215
Phone: 913.338.2886
Fax: 913.338.2879
techserv@procharger.com**

**Accessible Technologies, Inc.
©2016 ATI, All Rights Reserved
Part Number PMGY1A-001 Rev. F**

