

# Front and Rear Suspension Modification Kit Installation

**Table 1:** [Kit Contents](#)

**Table 2:** [Front and Rear Suspension Modification Kit Installation](#)

## Installation Instructions Part Number

84130609

## Chevrolet Camaro 1LE Suspension Kit

Thank you for choosing Chevrolet Performance as your high performance source. Chevrolet Performance is committed to providing proven, innovative performance technology that is truly... more than just power. Chevrolet Performance parts are engineered, developed and tested to exceed your expectations for fit and function. Please refer to our catalog for the Chevrolet Performance Authorized Center nearest you or visit our website at [www.chevroletperformance.com](http://www.chevroletperformance.com).

It is not the intent of these specifications to replace the comprehensive and detailed service practices explained in the GM service manuals. For detailed installation instructions please look to the service manual for your specific vehicle.

GM service manuals are available from: Helm Incorporated PO Box 07130 Detroit, MI 48207

For information about warranty coverage, please contact your local Chevrolet Performance parts dealer.

Observe all safety precautions and warnings in the service manuals when installing this kit in any vehicle. Wear eye protection and appropriate protective clothing. Support the vehicle securely with jack stands when working under or around it. Use only the proper tools. Exercise extreme caution when working with flammable, corrosive, and hazardous liquids and materials. Some procedures require special equipment and skills. If you do not have the appropriate training, expertise, and tools to perform any part of this conversion safely, this work should be done by a professional.

The information contained in this publication is presented without any warranty. All the risk for its use is entirely assumed by the user. Specific component design, mechanical procedures, and the qualifications of individual readers are beyond control of the publisher, and therefore the publisher disclaims all liability incurred in connection with the use of the information provided in this publication.

Chevrolet, Chevy, the Chevrolet Bow Tie Emblem, General Motors, and GM are all Registered trademarks of the General Motors Corporation.

### Kit Contents

Qty	Description
1	<b>Front Stabilizer Bar</b>
2	<b>Front Springs</b>
2	<b>Front Top Strut Mount</b>
1 each	<b>Front Handling Link (LH) &amp; (RH)</b>

2	<b>Rear Springs</b>
1	<b>Rear Stabilizer Bar</b>
2	<b>Nut Prevailing Torque</b>
1	<b>MR Calibration</b>
2	<b>Bolt – Front Handling Link</b>
2	<b>Bolt – Rear Lower Suspension</b>
2	<b>Bolt – Rear Lower Shock absorber</b>
1	<b>CHEVROLET PERFORMANCE EMBLEM</b>

**Recommended Tools**

- CH-42188-B Ball Joint Separator
- CH-45400-A Strut Spring Compressor
- CH-50732 Strut Rod Nut Socket, 18 mm
- J-36660-A Torque Angle Meter
- Torque Wrench (10-150 ft-lbs)

**Flash Programming**

This kit includes a calibration update for the Magnetorheological (MR) Fluid Dampers. Reprogramming is done with a Service Programming System at an Authorized GM Dealer. When reprogramming, the GM dealer needs to call the Techline Customer Support Center (TCSC). The TCSC will provide a Vehicle Configuration Index (VCI). The VCI is good for only one specific Vehicle Identification Number (VIN). Call TCSC (1-888-337-1010) to obtain a VCI number. You must have the vehicle's VIN that will be upgraded and the following Authorization Code.

**Note:** The use of a LOW PROFILE LIFT ARMS SYSTEM may be required to avoid unwanted contact with the vehicle's body and structure depending on lifting equipment used. Refer to the manufacture's recommendation for their applications of low profile lift arms system for their lifting equipment.

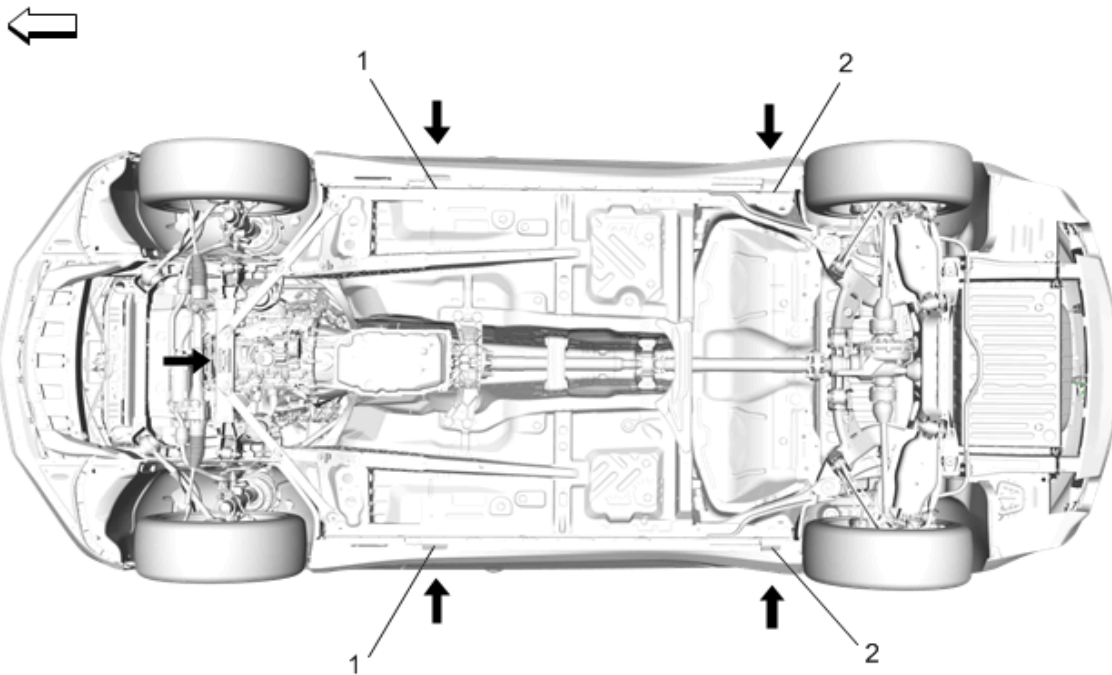

**Danger:** To avoid any vehicle damage, serious personal injury or death when major components are removed from the vehicle and the vehicle is supported by a hoist, support the vehicle with jack stands at the opposite end from which the components are being removed and strap the vehicle to the hoist.

**Danger:** To avoid any vehicle damage, serious personal injury or death, always use the jackstands to support the vehicle when lifting the vehicle with a jack.

**Caution:** Perform the following steps before beginning any vehicle lifting or jacking procedure:

- Remove or secure all of the vehicle contents in order to avoid any shifting or any movement that may occur during the vehicle lifting or jacking procedure.
- The lifting equipment or the jacking equipment weight rating must meet or exceed the weight of the vehicle and any vehicle contents.
- The lifting equipment or the jacking equipment must meet the operational standards of the lifting equipment or jacking equipment manufacturer.
- Perform the vehicle lifting or jacking procedure on a clean, hard, dry, level surface.
- Perform the vehicle lifting or jacking procedure only at the identified lift points. DO NOT allow the lifting equipment or jacking equipment to contact any other vehicle components.

Failure to perform the previous steps could result in damage to the lifting equipment or the jacking equipment, the vehicle, and/or the vehicle contents.

### **Vehicle Lifting- Frame Contact Lift**

**Note:** The vehicle should be lifted so that the hoist pads and or lift arms do not contact the rocker panel molding. The hoist pad must be

place the lift pads on the rocker outer panel rear cradle brace. Care should be taken to ensure the hoist pad is inside the rocker panel molding cut out area (notch) to prevent damage to the vehicle.

### **Front Lift Pads**

When lifting the vehicle with a frame-contact lift, place the front lift pads on the rocker outer panel weld flange (1), as shown

### **Rear Lift Pads**

When lifting the vehicle with a frame-contact lift, place the rear lift pads on the rocker outer panel weld flange (2), as shown.

## **Vehicle Jacking**

**Caution:** When you are jacking the vehicle at the front locations, be certain that the jack or the jack lift pad does not contact the front fascia, front fascia air dam, or the front fenders. If such contact occurs, vehicle damage may result. When jacking at selected front locations additional clearance may be required for the jacking points.

**Note:** When you are lifting a vehicle with a service jack, block the wheels at the opposite end from which you are lifting. Use jack stands to provide additional support.

### **Front of Vehicle**

When using a service jack under the front of the vehicle use one of the following locations:

Place the service jack pad in the same location as shown for the front lift pads or on the front center jack pad.

### **Rear of Vehicle**

**Note:** Place jackstands ONLY under strong and stable vehicle structures.

Place the service jack pad in the same location as shown for the rear lift pads.

### **Fastener Caution**

Use the correct fastener in the correct location. Replacement fasteners must be the correct part number for that application. Do not use paints, lubricants, or corrosion inhibitors on fasteners, or fastener joint surfaces, unless specified. These coatings affect fastener torque and joint clamping force and may damage the fastener. Use the correct tightening sequence and specifications when installing fasteners in order to avoid damage to parts and systems. When using fasteners that are threaded directly into plastic, use extreme care not to strip the mating plastic part(s). Use hand tools only, and do not use any kind of impact or power tools. Fastener should be hand tightened, fully seated, and not stripped.

### **Torque to Yield Fastener Warning**

This vehicle is equipped with torque-to-yield or single use fasteners. Install a NEW torque-to-yield or single use fastener when installing this component. Failure to replace the torque-to-yield or single use fasteners could cause damage to the vehicle, component, or bodily injury.

## **Front Lower Control Rear Link Replacement (LT1)**

### **Special Tools**

CH-42188-B Ball Joint Separator

Equivalent regional tools: [Special Tools](#)

## Removal Procedure



1. Front Wheelhouse Splash Shield (1) » Remove — [Front Wheelhouse Splash Shield Replacement](#)

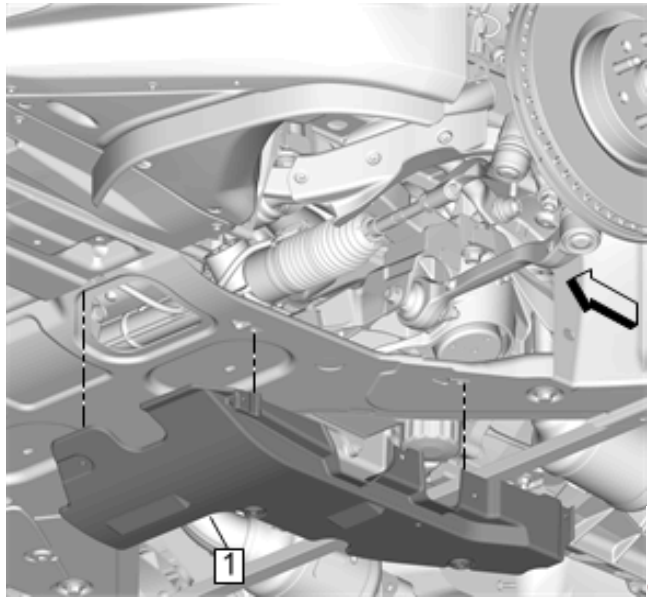

2. Front Compartment Side Noise Shield (1) » Remove — [Front Compartment Side Noise Shield Replacement](#)

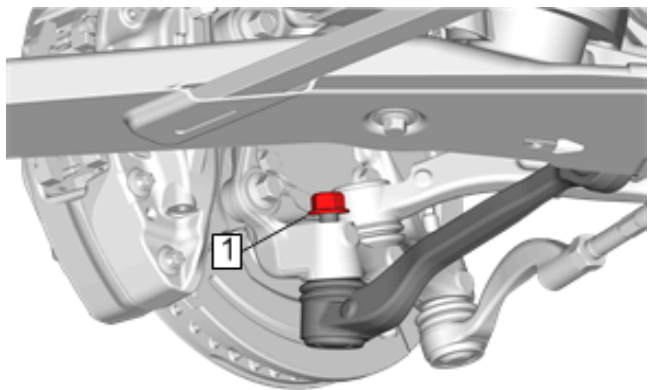

3. Steering Knuckle Nut (1) » Loosen  
Do NOT remove the nut.

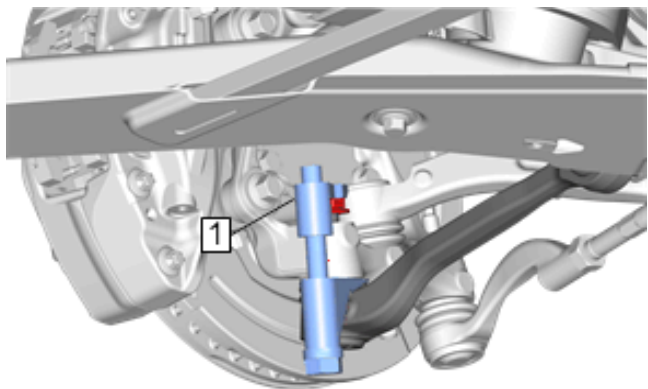

4. Use the *CH-42188-B* separator (1) to separate the front lower control front link from the steering knuckle.

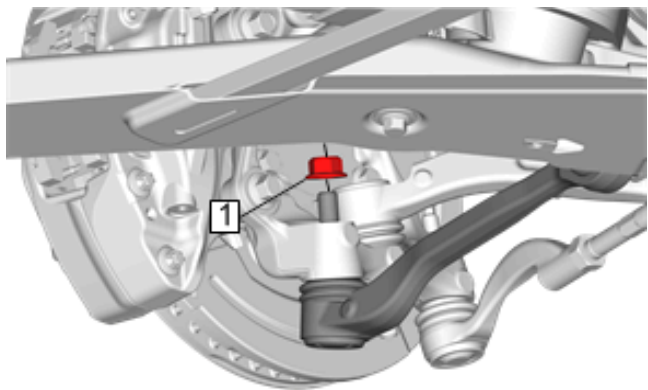

5. Steering Knuckle Nut (1) » Remove

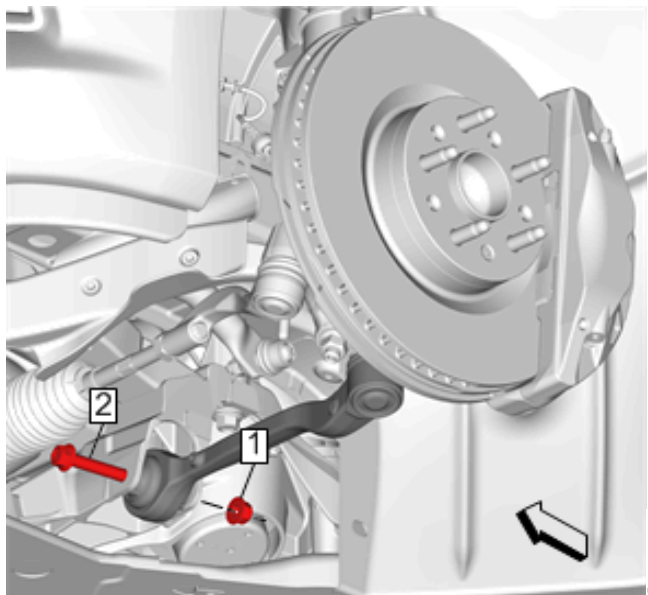

6. Front Lower Control Rear Link Nut (1) » Remove

**Caution:** Use caution when removing components surrounding the Steering Gear Boots. Avoid tool contact with the steering gear boot and clamps. Damage to the steering gear boot may lead to dirt and water contamination in the steering gear rack and components requiring a preventable replacement of the Steering Gear and its Components.

7. Front Lower Control Rear Link Bolt (2) » Remove  
DISCARD the bolt.

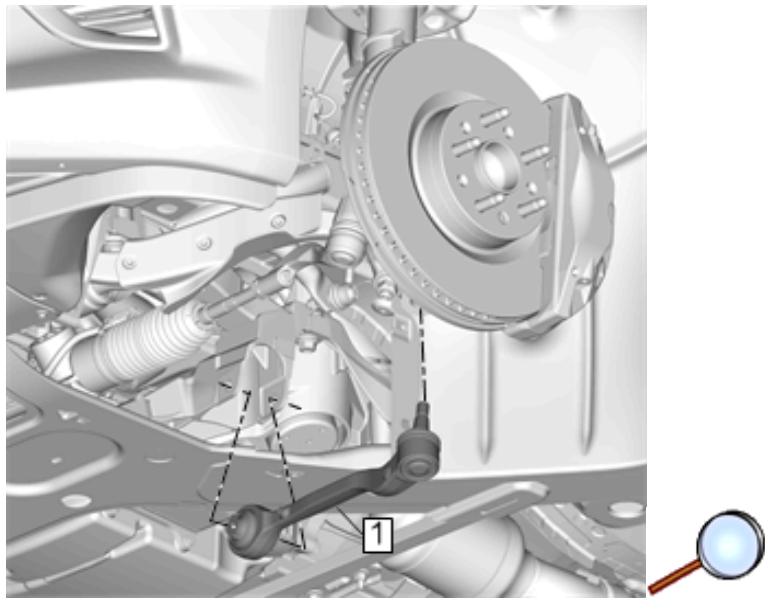

8. Remove the front lower control rear link (1) from the vehicle.

### Installation Procedure

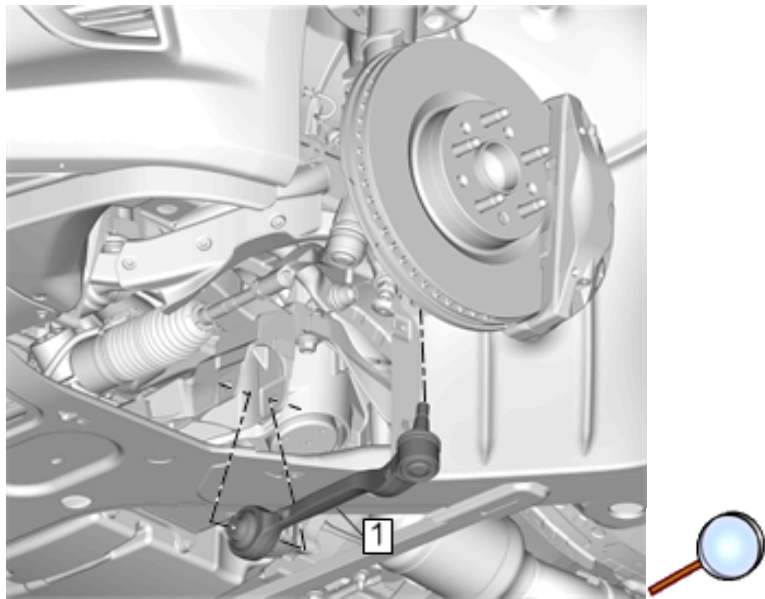

1. Position the front lower control rear link (1) on the vehicle.

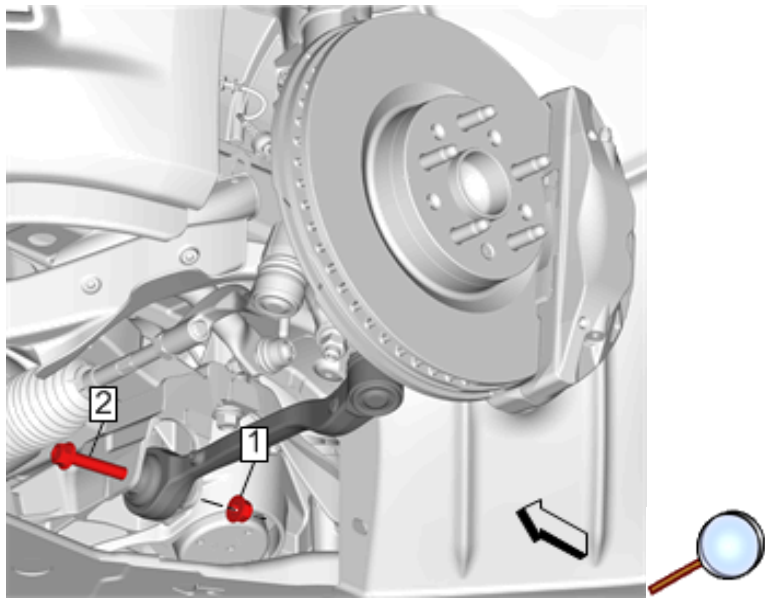

**Caution:** This vehicle is equipped with torque-to-yield or single use fasteners. Install a NEW torque-to-yield or single use fastener when installing this component. Failure to replace the torque-to-yield or single use fastener could cause damage to the vehicle or component.

2. Front Lower Control Rear Link Bolt (2) » Install  
Install a NEW bolt.

3. Front Lower Control Rear Link Nut (1) » Install

**Caution:** Refer to [Fastener Caution](#).

4. Front Lower Control Rear Link Bolt (2) » Tighten

**Tighten**

4.1. First Pass: **100N•m (74 lb ft)**

4.2. Final Pass: **(90–105 degrees)**

5. Inspect steering gear boot for damage. If any damage is noted, replace the steering gear boot. [Steering Gear Boot Replacement](#)

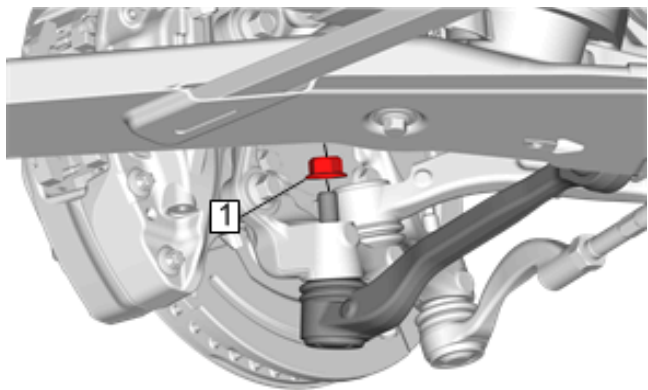

6. Steering Knuckle Nut (1) » Install and tighten

**Tighten**

6.1. First Pass: **40N•m (30 lb ft)**

6.2. Final Pass: **(120–135 degrees)**

**[Stabilizer Shaft Replacement \(LT1\)](#)**

**Removal Procedure**

1. Remove the front tire and wheel assemblies. [Tire and Wheel Removal and Installation](#)

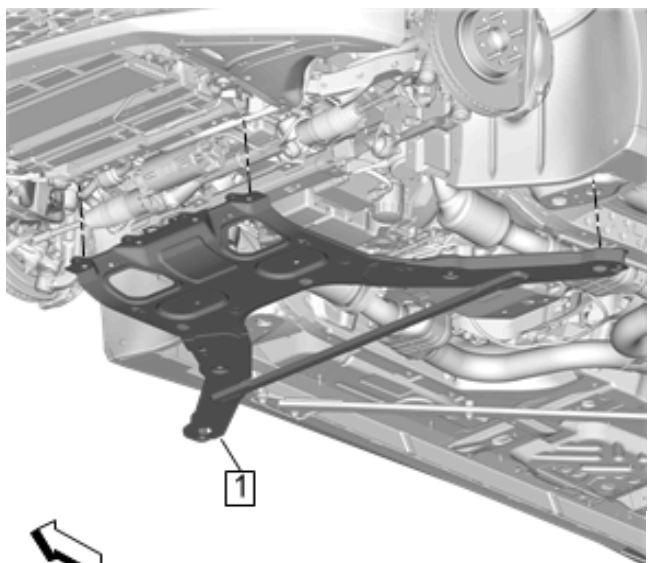

2. Front Cradle Shear Plate (1) » Remove — [Front Cradle Shear Plate Replacement](#)

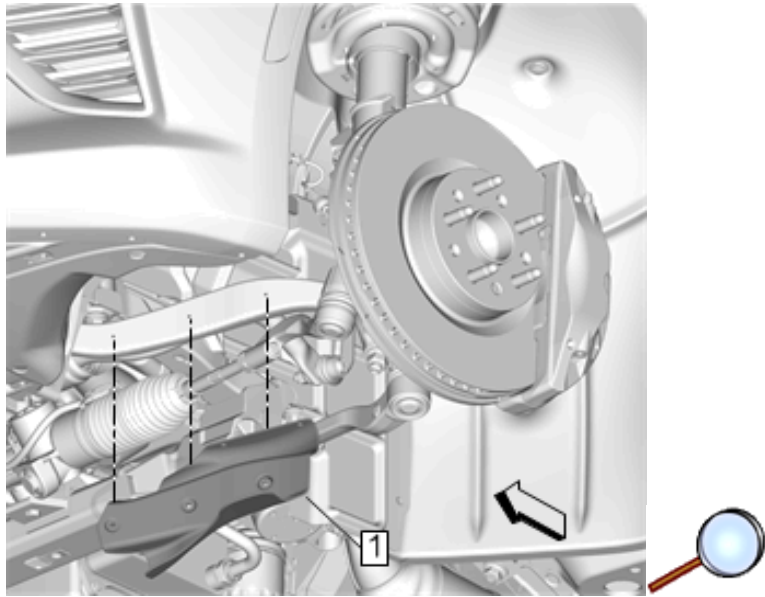

3. Front Brake Rotor Cooling Duct Deflector (1) » Remove [2x] — [Front Brake Rotor Cooling Duct Deflector Replacement](#)

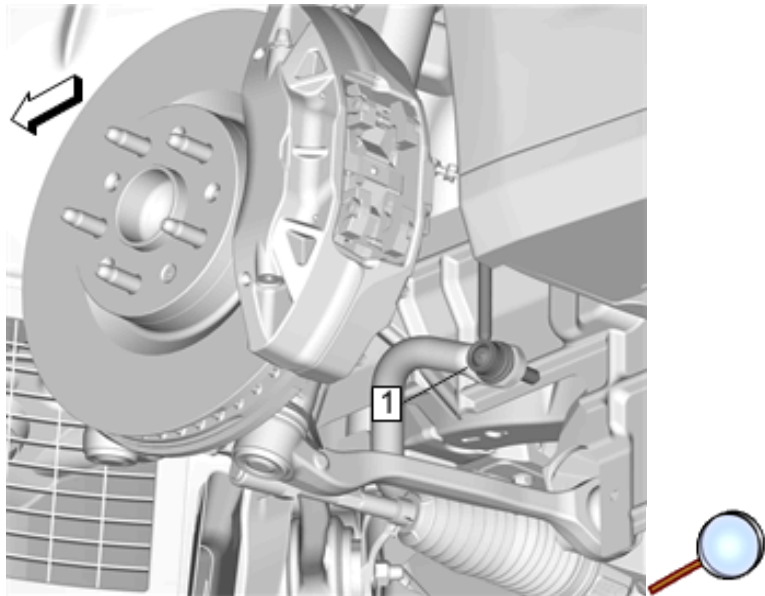

4. Front Stabilizer Shaft Link (1) @ Front Stabilizer Shaft » Separate [2x] — [Stabilizer Shaft Link Replacement](#)

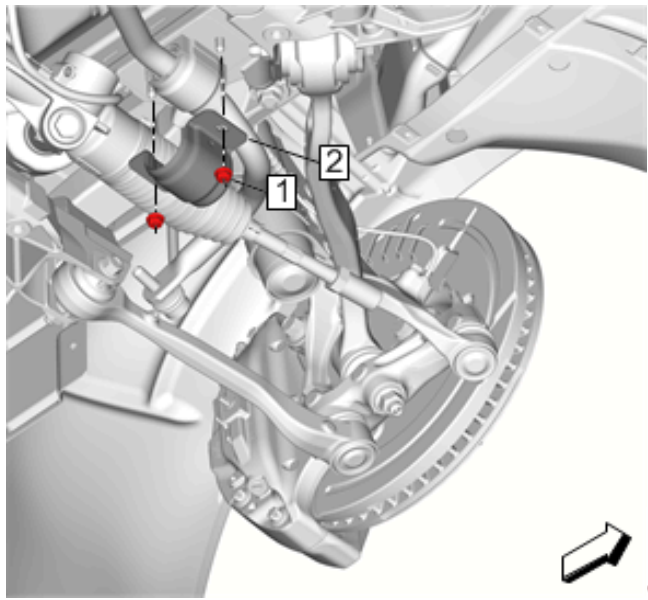

**Caution:** Use caution when removing components surrounding the Steering Gear Boots. Avoid tool contact with the steering gear boot and clamps. Damage to the steering gear boot may lead to dirt and water contamination in the steering gear rack and components requiring a preventable replacement of the Steering Gear and its Components.

5. Using a swivel socket, remove the left side front stabilizer shaft insulator clamp nuts (1) and clamp (2).

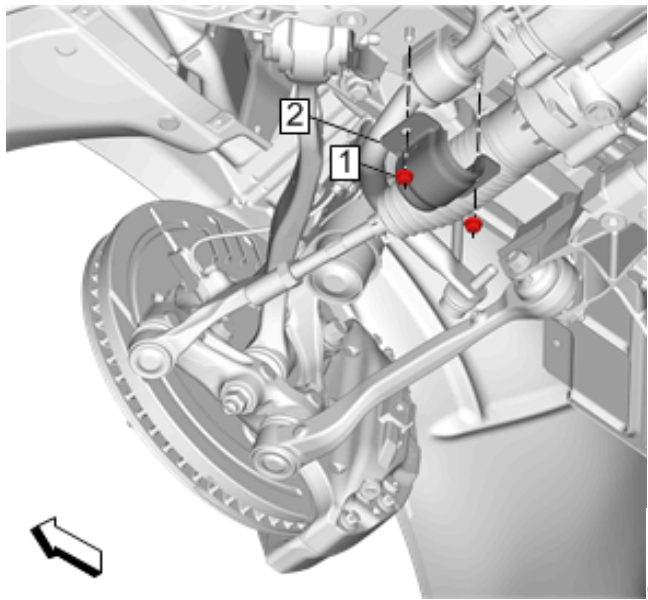

**Caution:** Use caution when removing components surrounding the Steering Gear Boots. Avoid tool contact with the steering gear boot and clamps. Damage to the steering gear boot may lead to dirt and water contamination in the steering gear rack and components requiring a preventable replacement of the Steering Gear and its Components.

6. Using a swivel socket, remove the right side front stabilizer shaft insulator clamp nuts (1) and clamp (2).

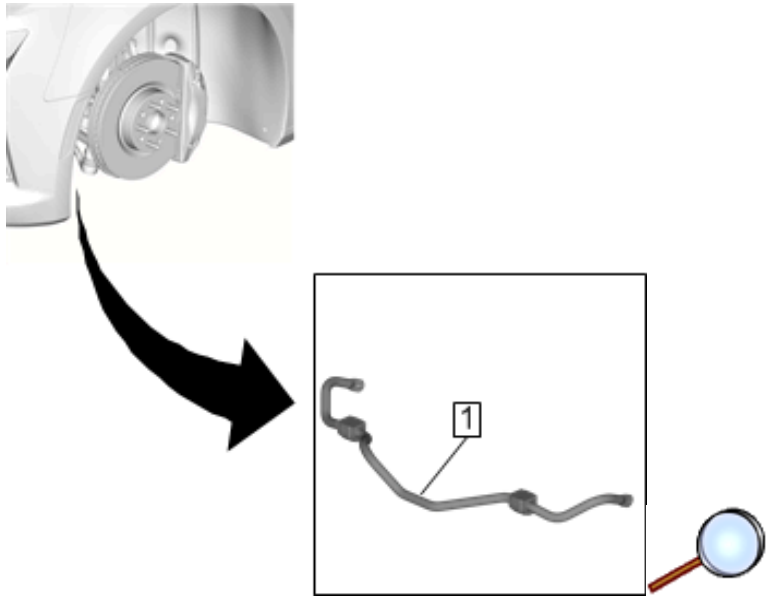

- Note:** The front stabilizer shaft insulators are NOT serviceable. Do NOT transfer the insulators.
7. Remove the front stabilizer shaft (1) from the vehicle.

### Installation Procedure

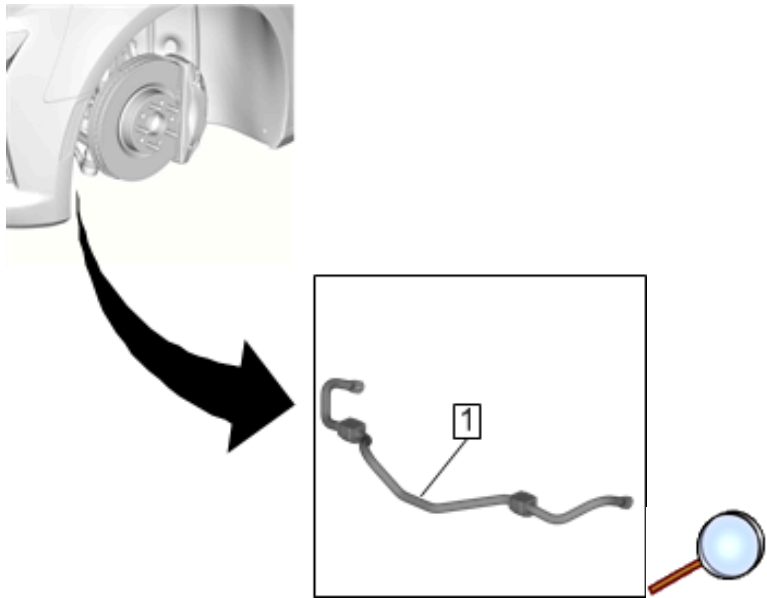

1. Position the front stabilizer shaft (1) on the vehicle.

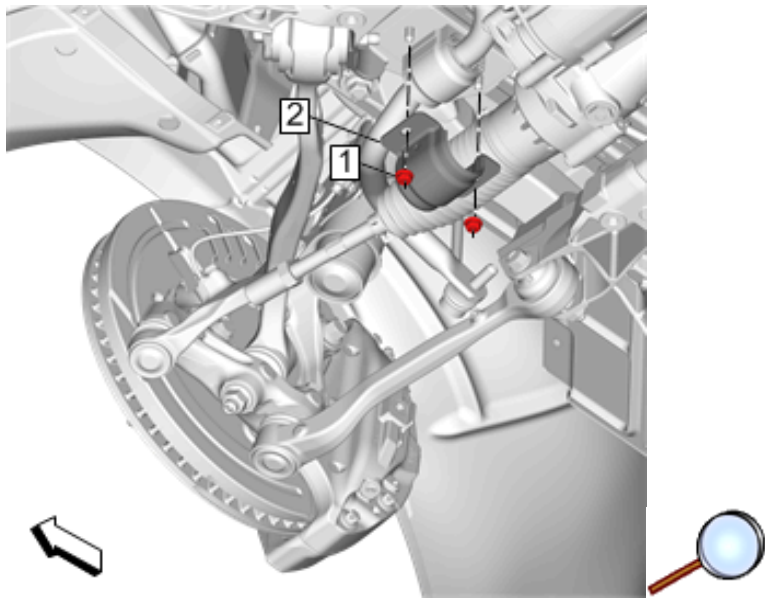

**Caution:** Refer to [Fastener Caution](#).

**Caution:** Use caution when removing components surrounding the Steering Gear Boots. Avoid tool contact with the steering gear boot and clamps. Damage to the steering gear boot may lead to dirt and water contamination in the steering gear rack and components requiring a preventable replacement of the Steering Gear and its Components.

- Using a swivel socket, install the right side front stabilizer shaft insulator clamp (2) and nuts (1) and tighten the nuts to **22N•m (16 lb ft)**.

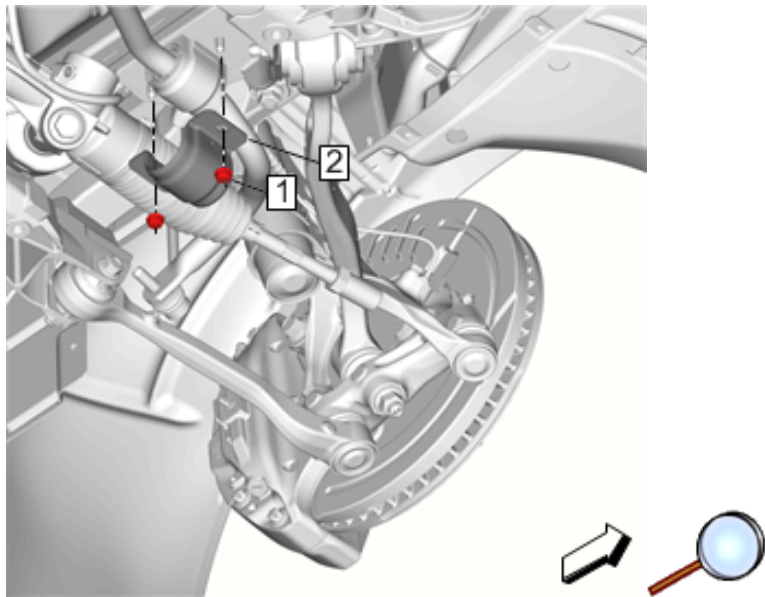

**Caution:** Use caution when removing components surrounding the Steering Gear Boots. Avoid tool contact with the steering gear boot and clamps. Damage to the steering gear boot may lead to dirt and water contamination in the steering gear rack and components requiring a preventable replacement of the Steering Gear and its Components.

- Using a swivel socket, install the left side front stabilizer shaft insulator clamp (2) and nuts (1) and tighten the nuts to **22N•m (16 lb ft)**.

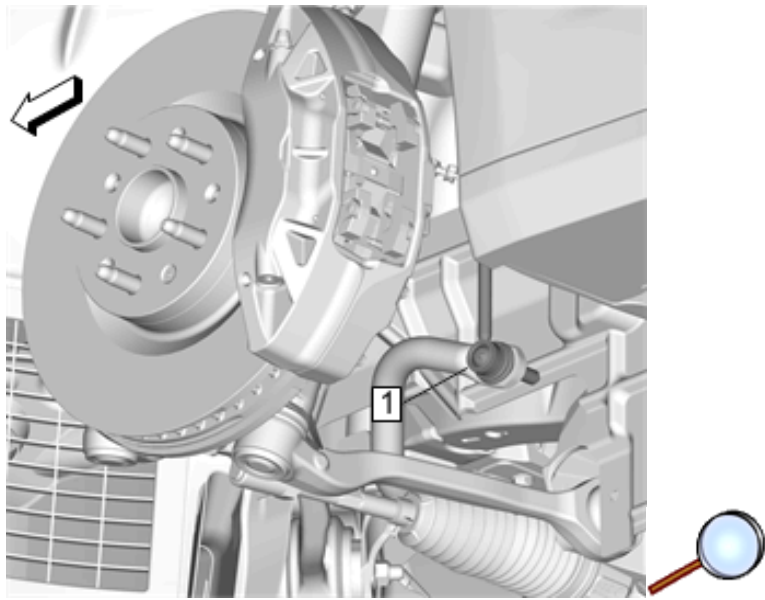

4. Front Stabilizer Shaft Link (1) @ Front Stabilizer Shaft » Install [2x] — [Stabilizer Shaft Link Replacement](#)

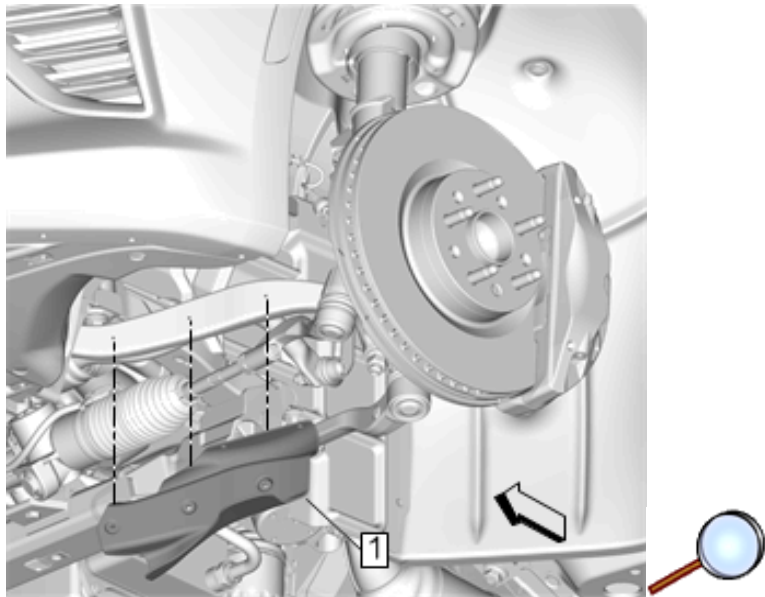

5. Front Brake Rotor Cooling Duct Deflector (1) » Install [2x] — [Front Brake Rotor Cooling Duct Deflector Replacement](#)

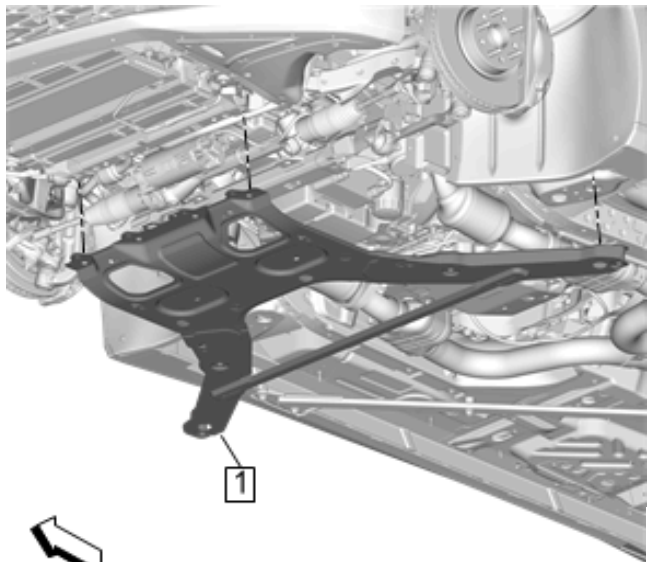

6. Front Cradle Shear Plate (1) » Install — [Front Cradle Shear Plate Replacement](#)

7. Install the front tire and wheel assemblies. [Tire and Wheel Removal and Installation](#)

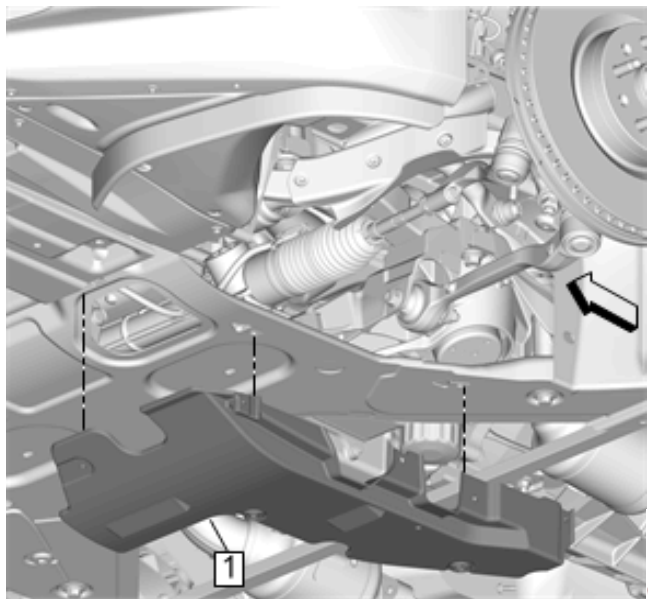

8. Front Compartment Side Noise Shield (1) » Install — [Front Compartment Side Noise Shield Replacement](#)

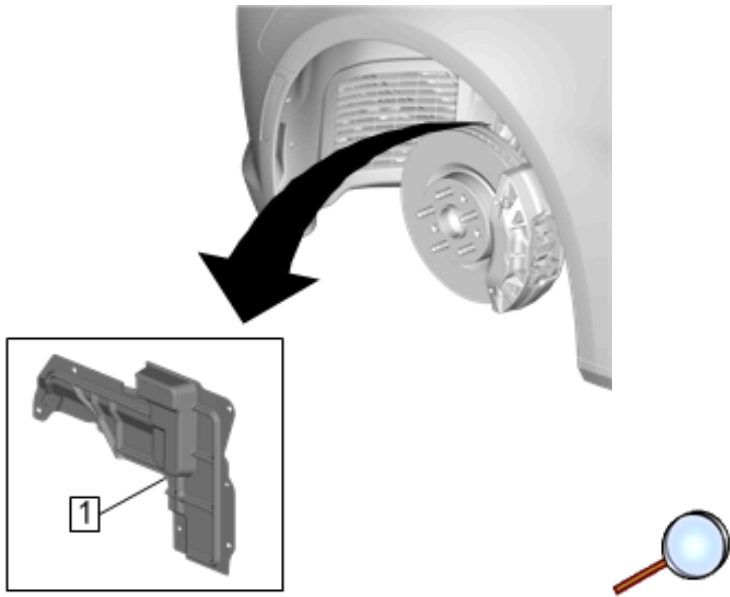

9. Front Wheelhouse Splash Shield (1) » Install — [Front Wheelhouse Splash Shield Replacement](#)

### **Strut Assembly Removal and Installation (LT1, With or Without F55)**

#### **Removal Procedure**

1. Remove the front tire and wheel assembly. [Tire and Wheel Removal and Installation](#)
2. { If equipped } Electrical Connector @ Strut Assembly » Disconnect

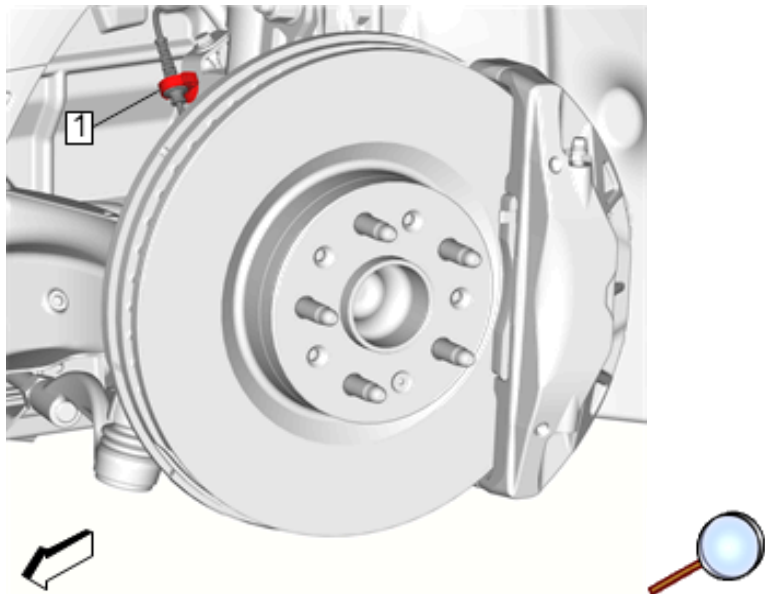

3. Front Wheel Speed Sensor Wiring Harness (1) @ Strut Assembly » Separate — [Front Wheel Speed Sensor Replacement](#)

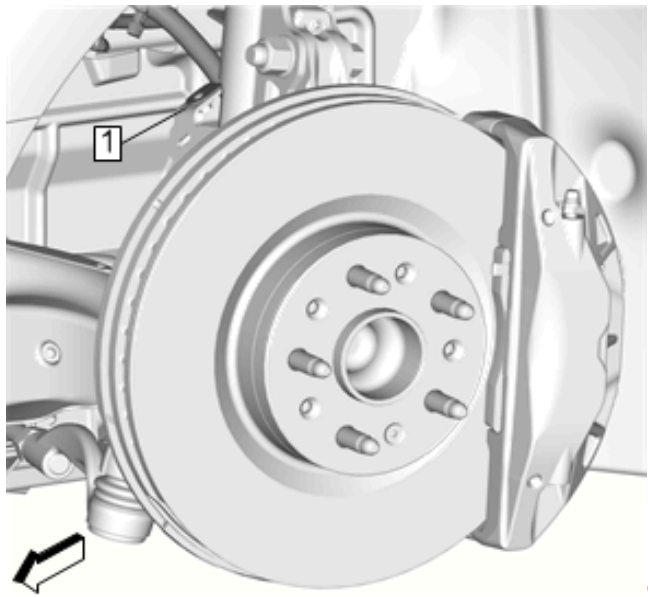

4. Front Brake Hose (1) @ Strut Assembly » Separate — [Front Brake Hose Replacement](#)

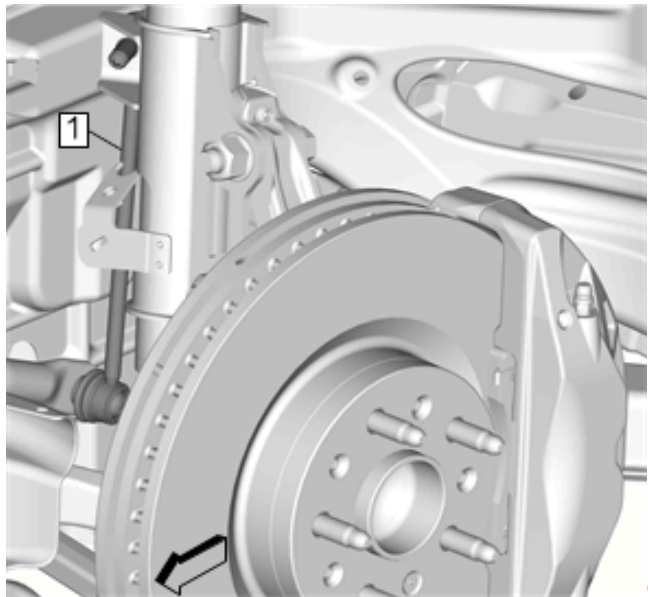

5. Front Stabilizer Shaft Link (1) @ Strut Assembly » Separate — [Stabilizer Shaft Link Replacement](#)

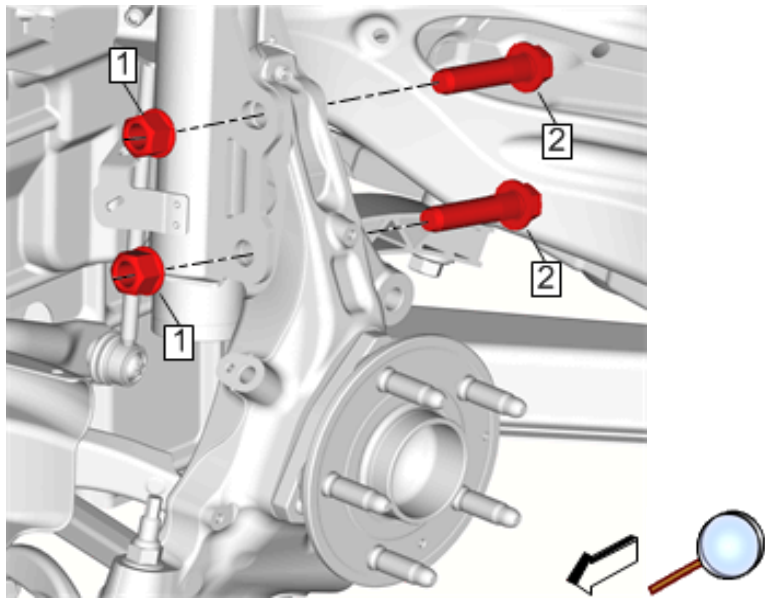

6. Front Suspension Strut Nut (1) » Remove [2x]

7. Front Suspension Strut Bolt (2) » Remove [2x]

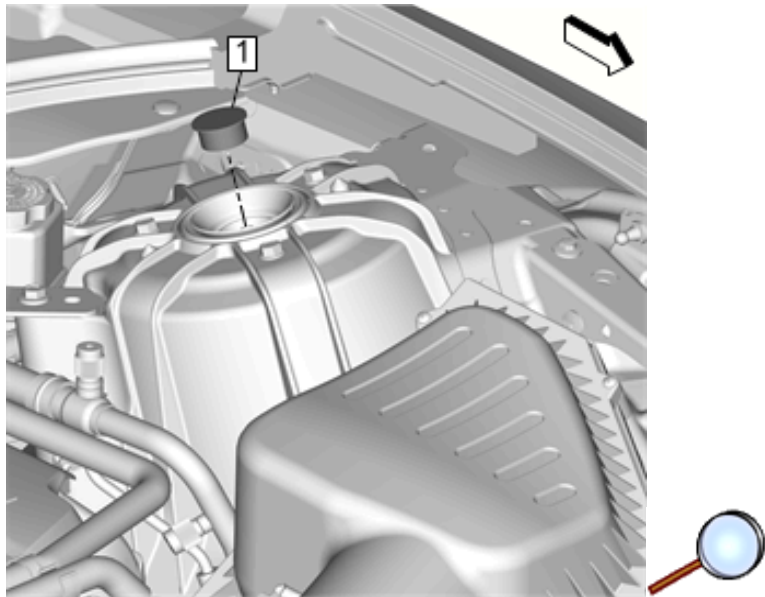

8. Front Suspension Strut Upper Mounting Cap (1) » Remove

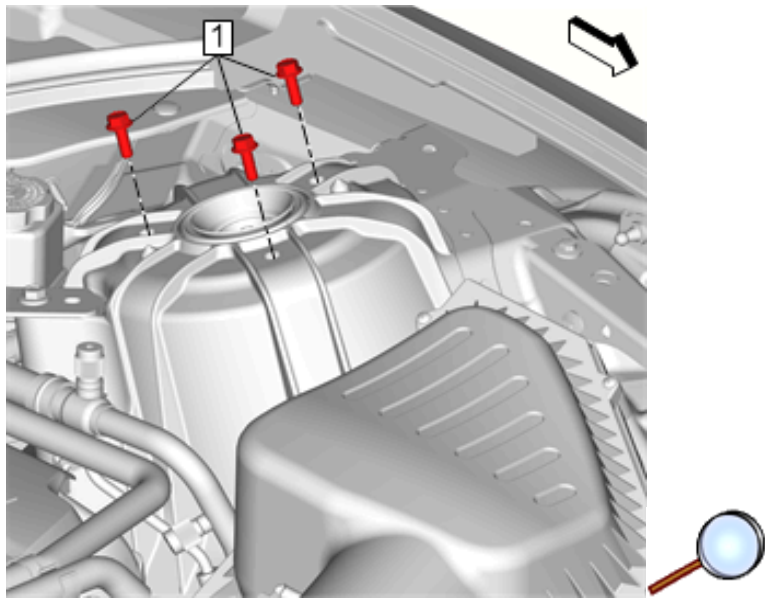

9. Front Suspension Strut Upper Mounting Bolt (1) » Remove [3x]

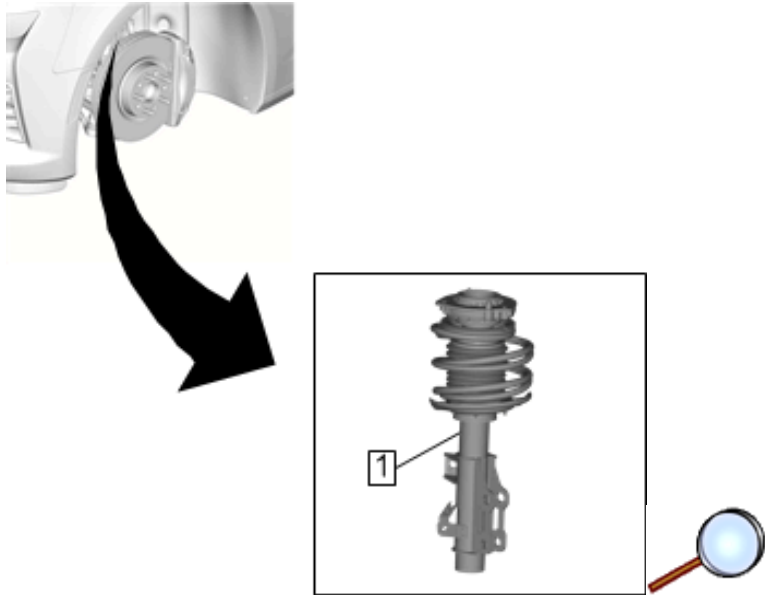

10. Remove the front suspension strut assembly (1) from the vehicle.

11. Transfer components as necessary.

[Strut, Strut Component, or Spring Replacement \(FE3, With F55\)](#)

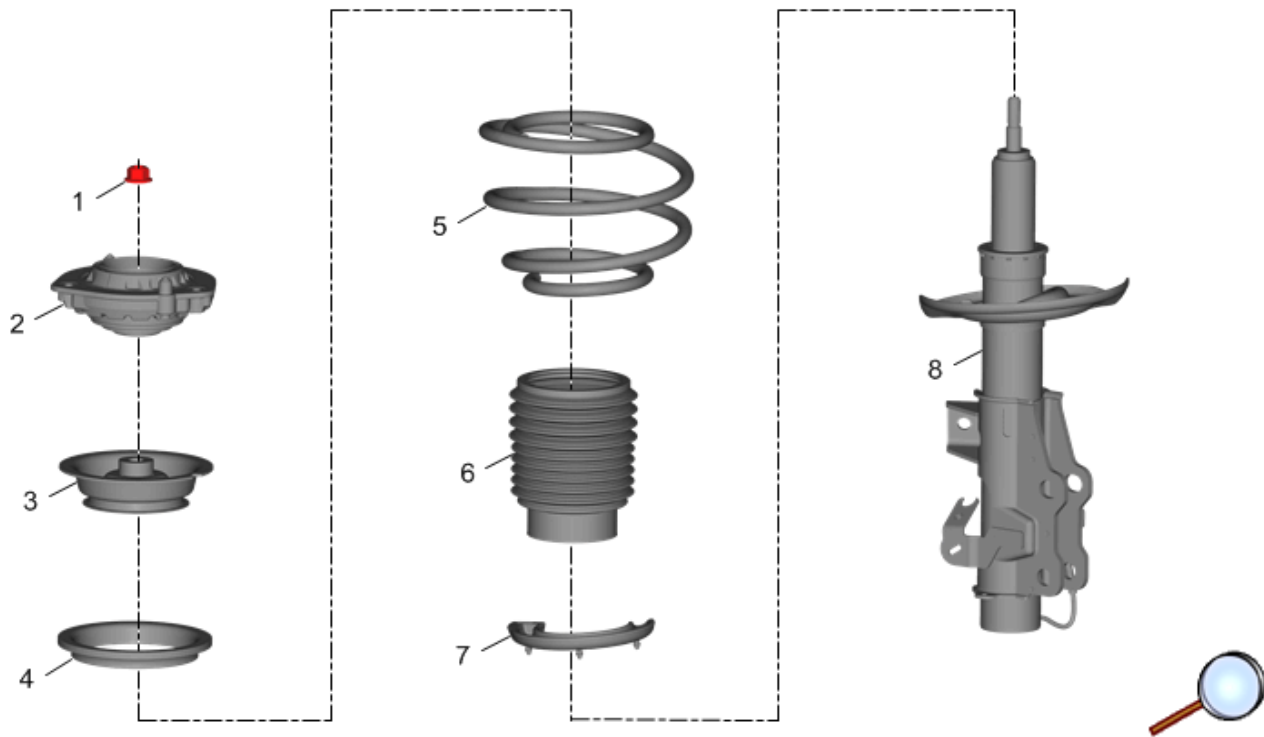

### Front and Rear Suspension Modification Kit Installation

Callout	Component Name
<p><b>Warning:</b> To prevent personal injury and/or component damage, use the proper tools to support and compress the coil spring prior to removal of the strut shaft nut when removing the coil spring. The coil spring is under extreme pressure and can become a projectile should the spring separate from the strut before all of the tension is relieved.</p>	
<p><b>Preliminary Procedure</b>  <a href="#">Strut Assembly Removal and Installation</a></p>	
1	<p>Front Suspension Strut Mount Nut</p> <p><b>Caution:</b> Refer to <a href="#">Fastener Caution</a>.</p> <p><b>Procedure</b></p> <ol style="list-style-type: none"> <li>1. Use the <i>CH-45400-A</i> compressor to compress the front coil spring.</li> <li>2. Use the <i>CH-50732</i> socket to remove and install the front suspension strut mount nut.</li> </ol> <p><b>Tighten</b>            50N•m (37 lb ft)</p> <p><b>Special Tools</b></p> <ul style="list-style-type: none"> <li>• <i>CH-45400-A</i> Strut Spring Compressor</li> <li>• <i>CH-50732</i> Strut Rod Nut Socket, 18 mm</li> </ul>

	Equivalent regional tools: <a href="#">Special Tools</a>
2	Front Suspension Strut Mount
3	Front Coil Spring Upper Seat
4	Front Coil Spring Upper Insulator
5	Front Coil Spring <b>Note:</b> Do NOT blemish or modify the coating on the front coil spring in any manner.
6	Front Strut Boot
7	Front Coil Spring Lower Insulator
8	Front Suspension Strut

### Strut Installation Procedure

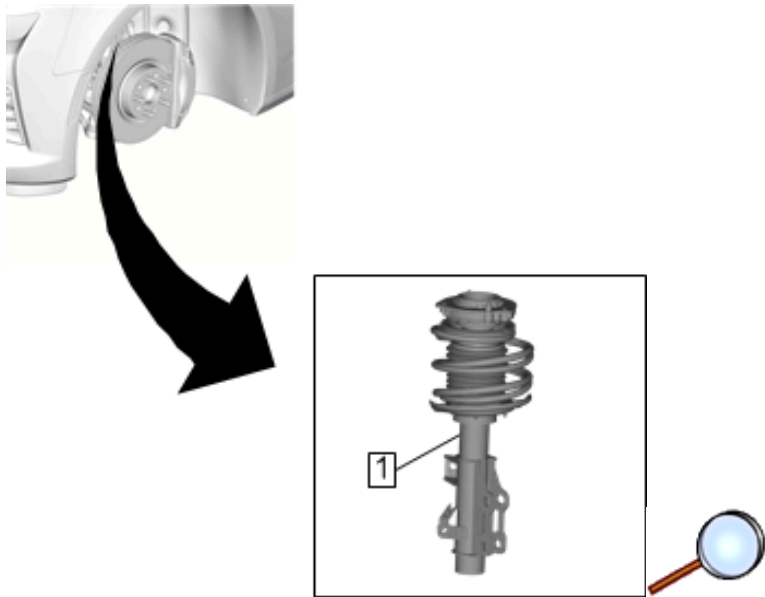

1. Position the front suspension strut assembly (1) on the vehicle.

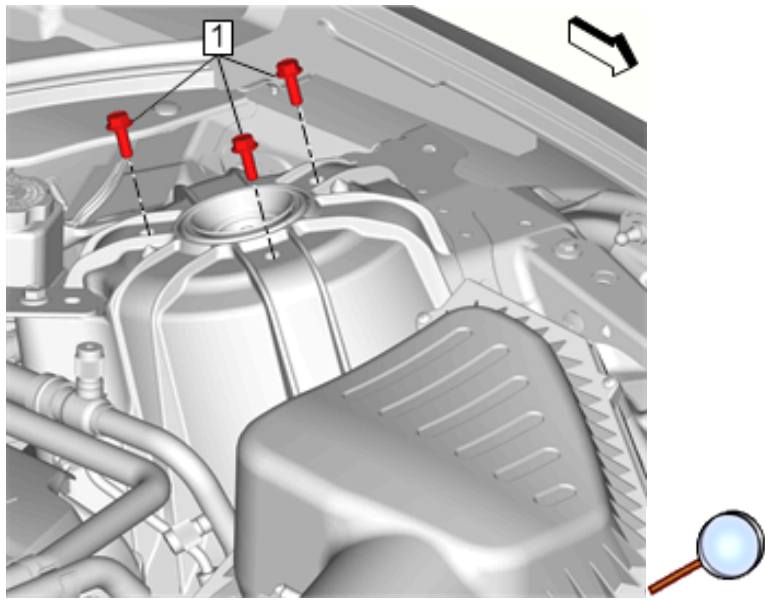

2. Front Suspension Strut Upper Mounting Bolt (1) » Install, but do NOT tighten [3x]

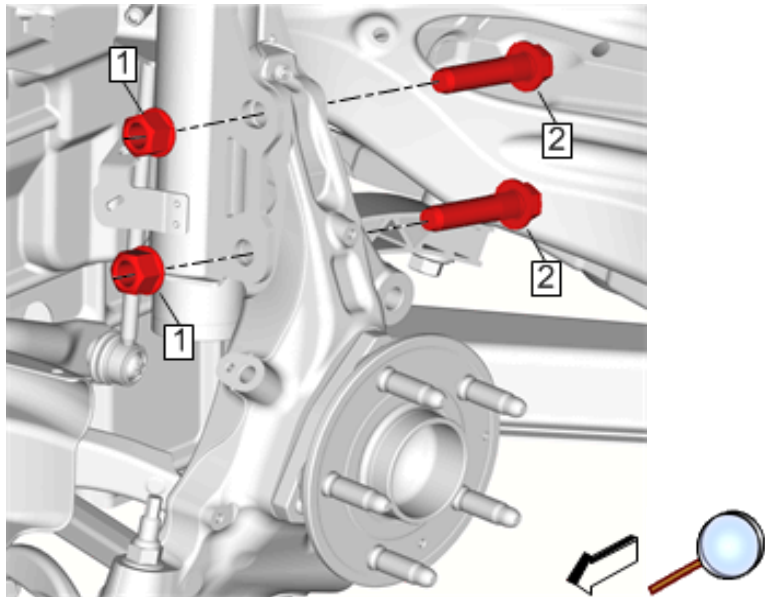

3. Front Suspension Strut Bolt (2) » Install [2x]

**Caution:** Refer to [Fastener Caution](#).

4. Front Suspension Strut Nut (1) » Install and tighten [2x]

**Tighten**

4.1. First Pass: **150N•m (111 lb ft)**

4.2. Final Pass: **(80–95 degrees)**

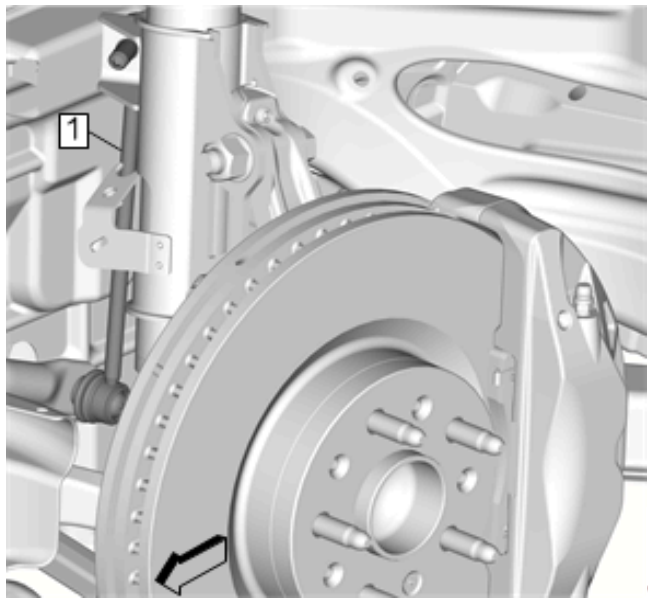

5. Front Stabilizer Shaft Link (1) @ Strut Assembly » Install — [Stabilizer Shaft Link Replacement](#)

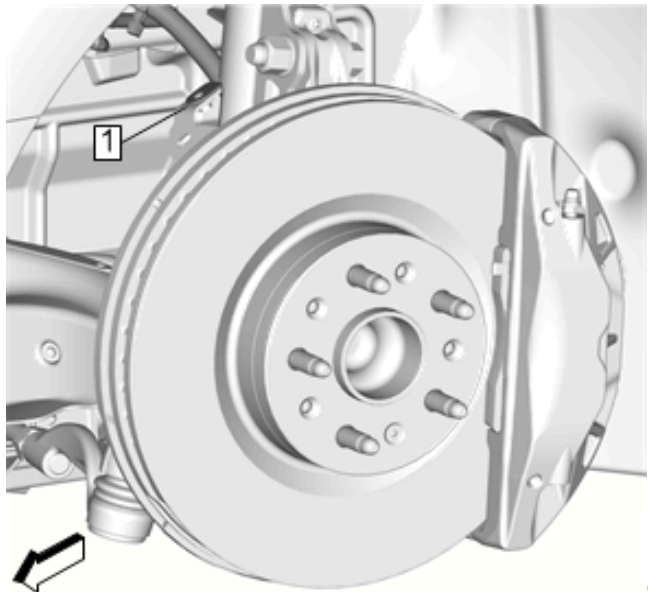

6. Front Brake Hose (1) @ Strut Assembly » Install — [Front Brake Hose Replacement](#)

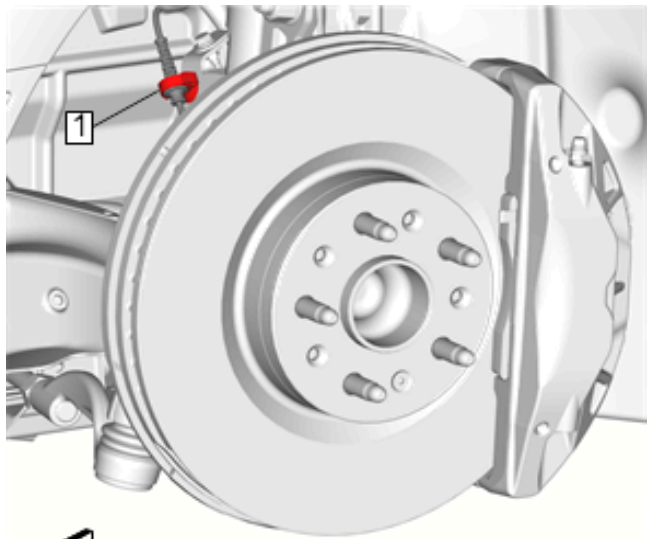

7. Front Wheel Speed Sensor Wiring Harness (1) @ Strut Assembly » Install — [Front Wheel Speed Sensor Replacement](#)

8. { If equipped } Electrical Connector @ Strut Assembly » Connect

9. Install the front tire and wheel assembly. [Tire and Wheel Removal and Installation](#)

10. Lower the vehicle completely.

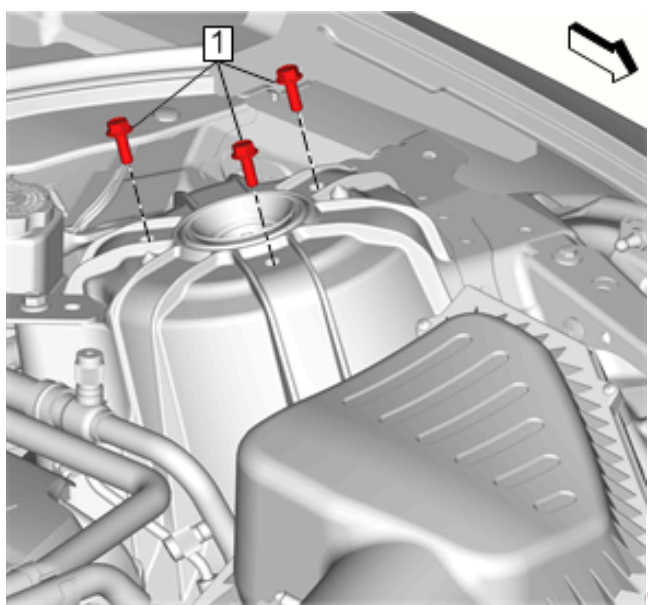

11. Front Suspension Strut Upper Mounting Bolt (1) » Tighten [3x]**22N•m (16 lb ft)**

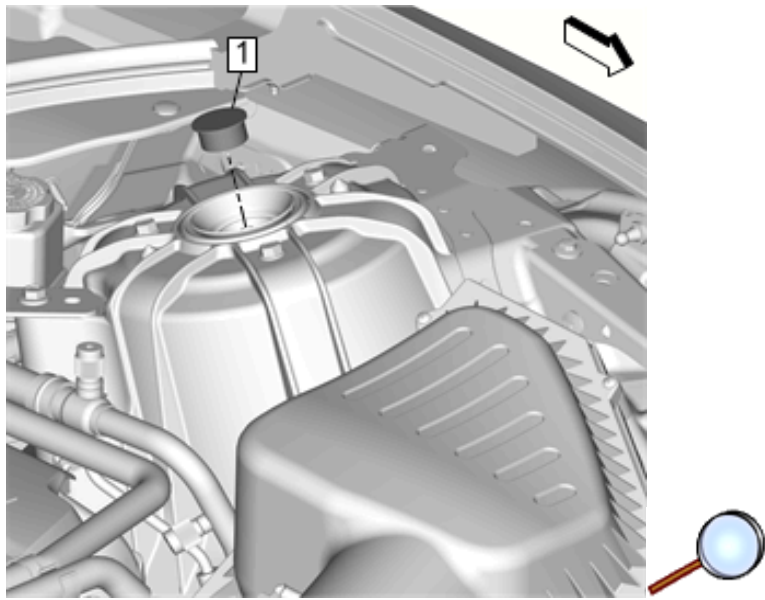

12. Front Suspension Strut Upper Mounting Cap (1) » Install

13. Measure and adjust the wheel alignment. [Wheel Alignment Measurement](#)

### [Rear Stabilizer Shaft Replacement \(FE3, FE4\)](#)

#### Removal Procedure

1. Remove the rear tire and wheel assemblies. [Tire and Wheel Removal and Installation](#)

**Caution:** Use care when removing or installing the stabilizer shaft as coating can be removed by contact with tools or other vehicle components. Corrosion will occur and early stabilizer shaft failure will be the result.

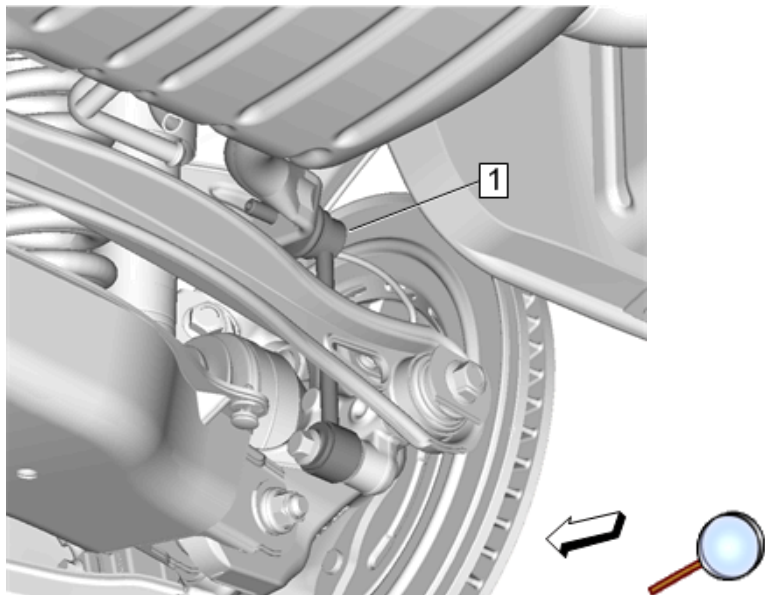

2. Rear Stabilizer Shaft Link (1) @ Right Side » Separate — [Stabilizer Shaft Link Replacement](#)

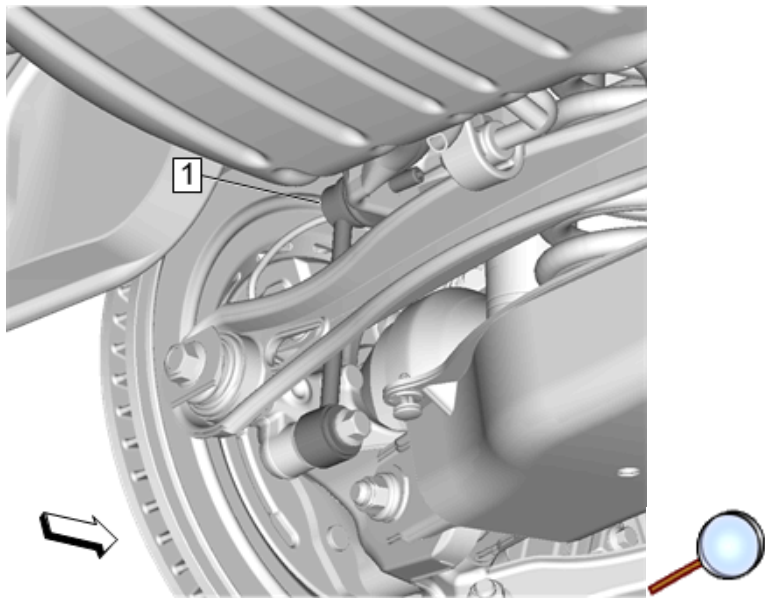

3. Rear Stabilizer Shaft Link (1) @ Left Side » Separate — [Stabilizer Shaft Link Replacement](#)

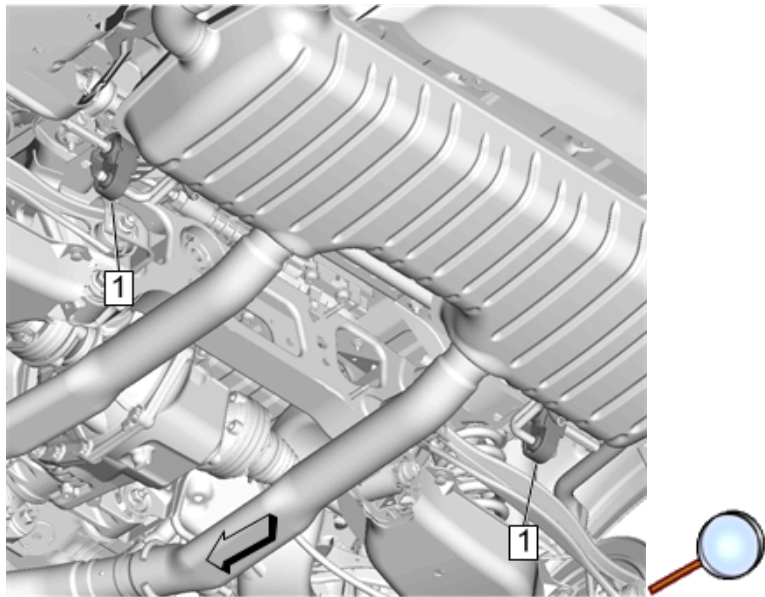

4. Remove the two rear exhaust muffler isolators. [Exhaust Muffler Replacement](#)

5. Remove the wiring harness from the top left stabilizer shaft insulator clamp bolt.

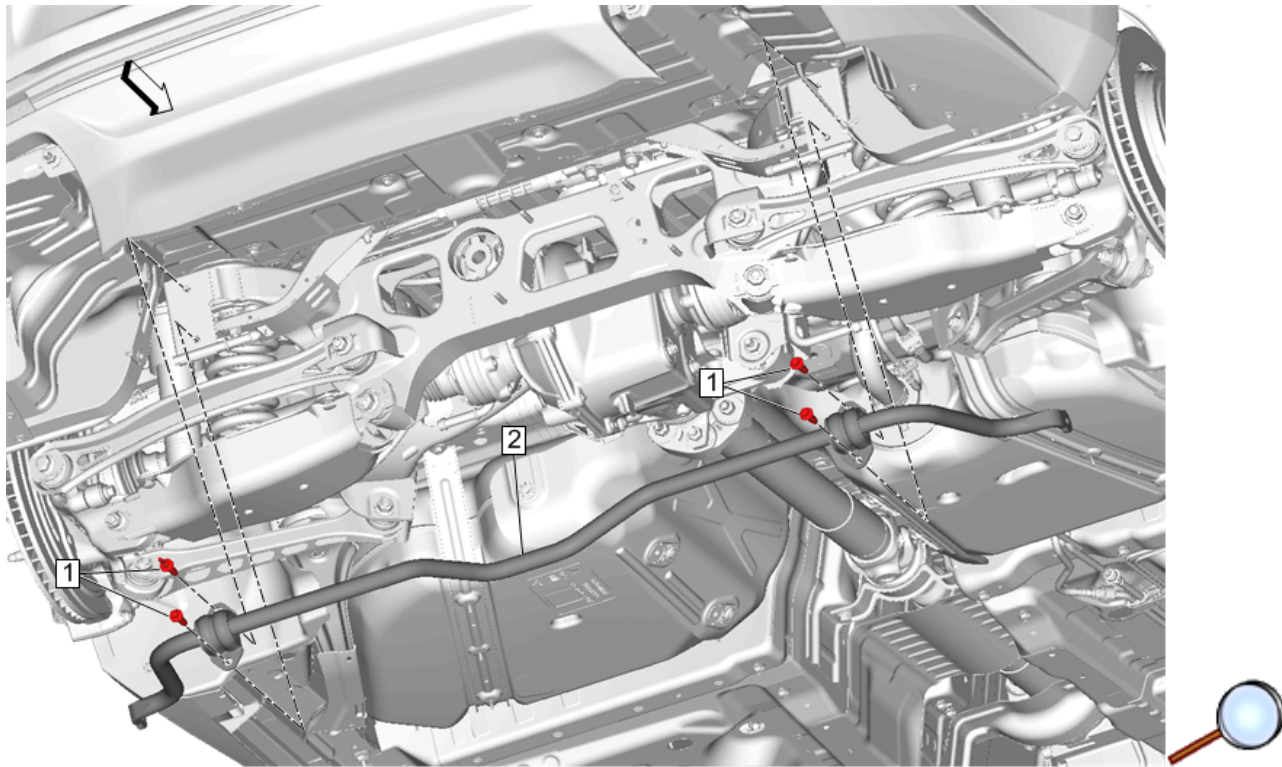

**Note:** The Exhaust Muffler is removed for illustration purposes only. It is not necessary to remove the Exhaust Muffler to remove the Stabilizer Shaft.

6. Rear Stabilizer Shaft Insulator Clamp Bolt (1) » Remove [4x]

7. Rear Stabilizer Shaft (2) » Remove

### **Installation Procedure**

**Caution:** Use care when removing or installing the stabilizer shaft as coating can be removed by contact with tools or other vehicle components. Corrosion will occur and early stabilizer shaft failure will be the result.



1. Prior to installation verify that the ID label (1) is on the right hand side of the vehicle.
2. Install the stabilizer shaft with the vehicle at curb height.

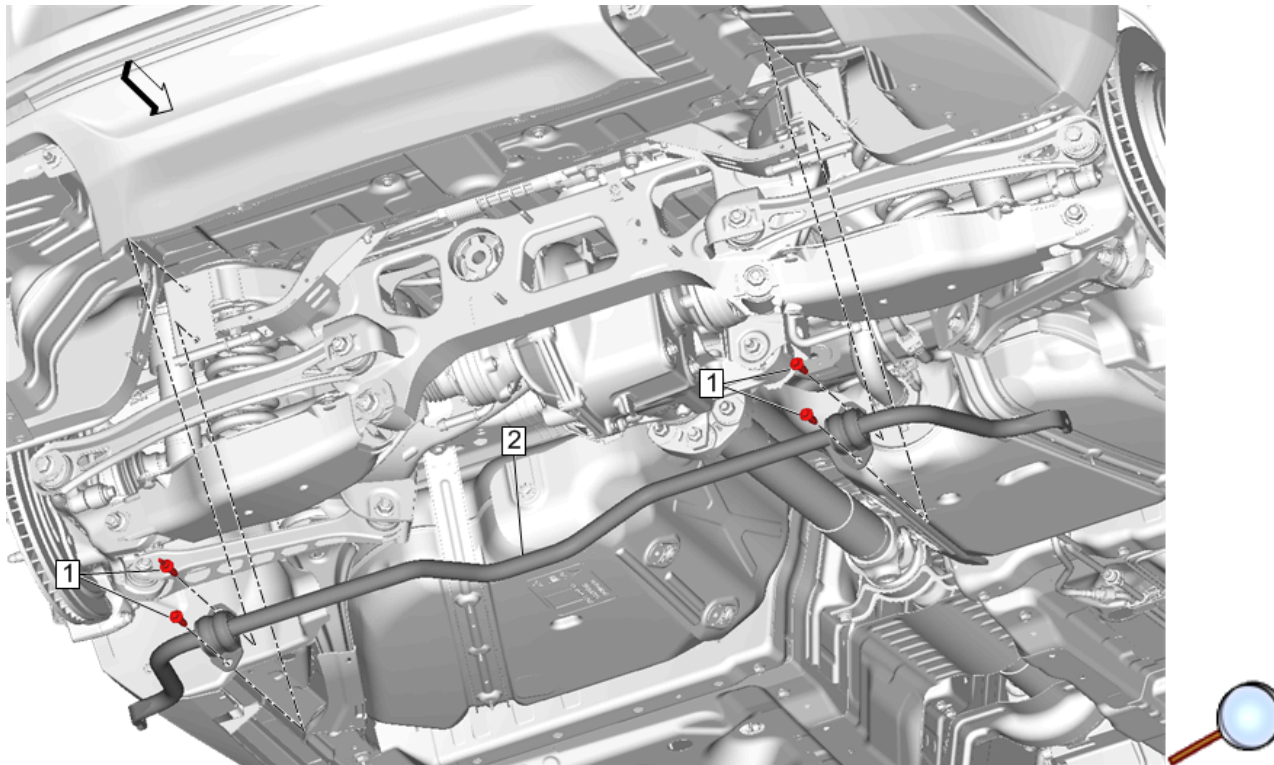

3. Rear Stabilizer Shaft (2) » Install
- Caution:** Refer to [Fastener Caution](#).
4. Rear Stabilizer Shaft Insulator Clamp Bolt (1) [4x] » Install and tighten **58N•m (43 lb ft)**
5. Install the wiring harness to the top left stabilizer shaft insulator clamp bolt.

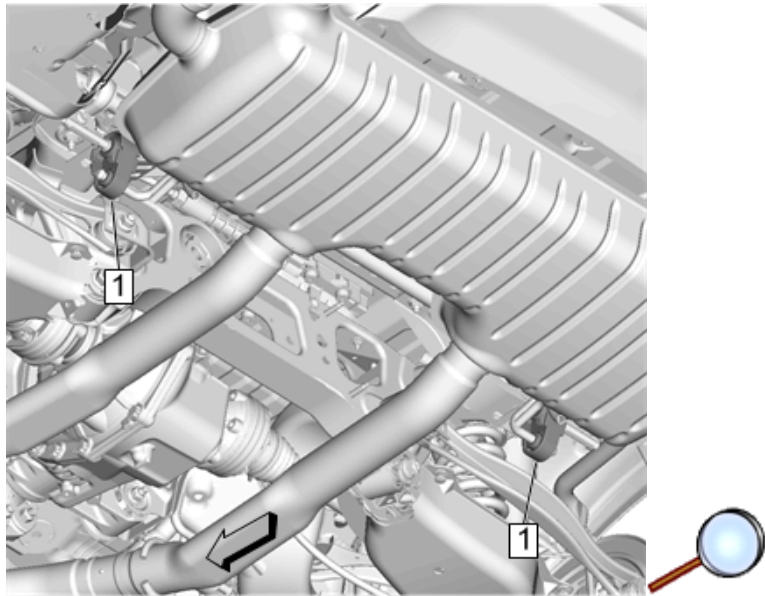

6. Install the two rear exhaust muffler isolators. [Exhaust Muffler Replacement](#)

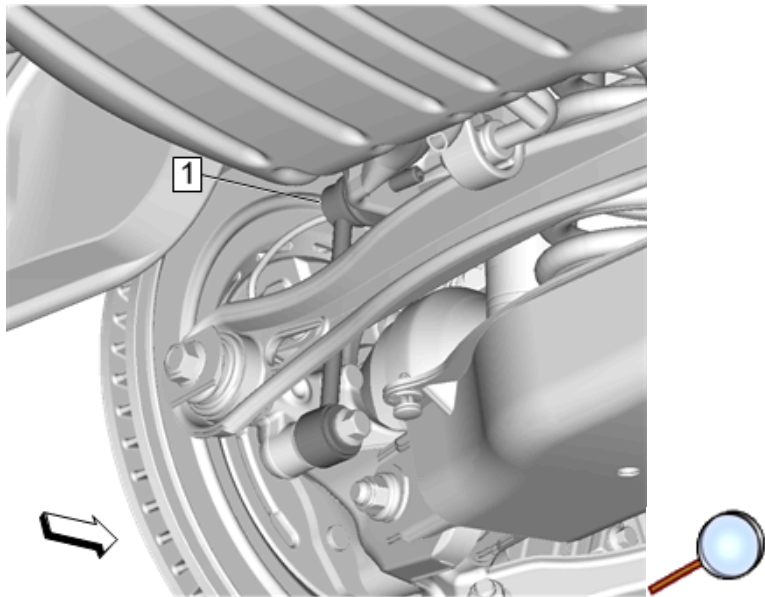

7. Rear Stabilizer Shaft Link (1) @ Left Side » Install — [Stabilizer Shaft Link Replacement](#)

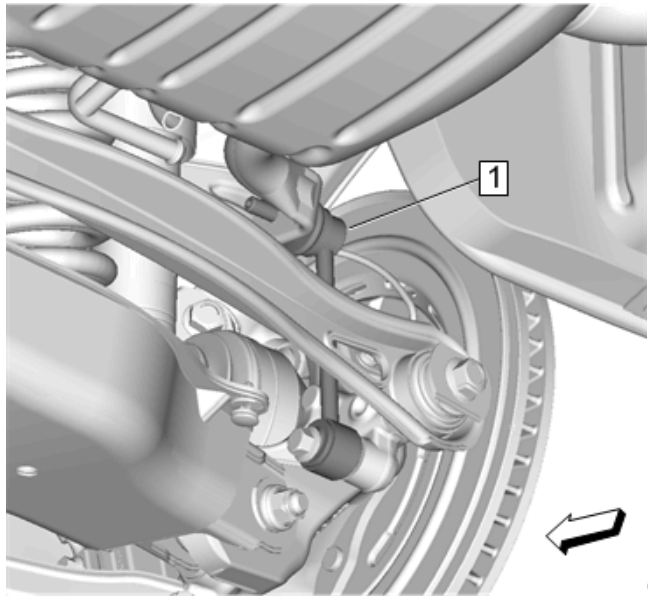

8. Rear Stabilizer Shaft Link (1) @ Right Side » Install — [Stabilizer Shaft Link Replacement](#)

9. Install the rear tire and wheel assemblies. [Tire and Wheel Removal and Installation](#)

## **[Rear Coil Spring Replacement](#)**

### **Procedure**

1. Raise and support the vehicle. Refer to [Lifting and Jacking the Vehicle](#).
2. Remove the tire and wheel assembly. Refer [Tire and Wheel Removal and Installation](#).
3. Remove the lower control arm. Refer to [Lower Control Arm Replacement](#).

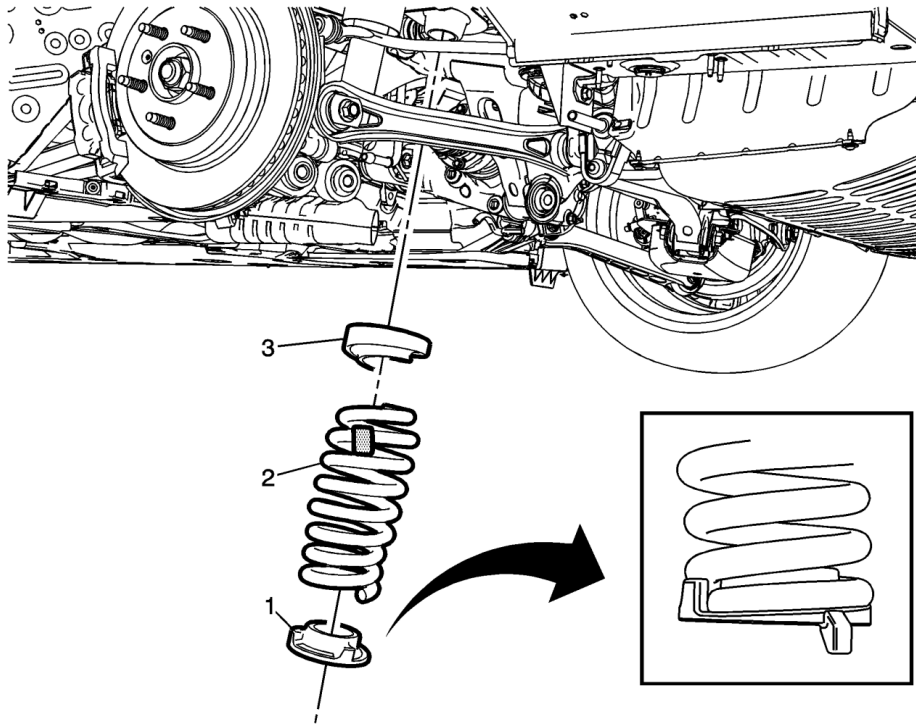

4. When installing the coil spring, ensure that the coil spring (2) is properly seated in both insulators (1), (3).
5. When installing the upper insulator (3) on the coil spring, ensure that the insulator stop is against the last coil on the spring.
6. When installing the lower insulator (1) on the coil spring, ensure that the insulator stop is against the last coil on the spring.

## **Lower Control Arm Replacement**

### **Special Tools**

*J-36660-A* Torque Angle Meter

### **Removal Procedure**

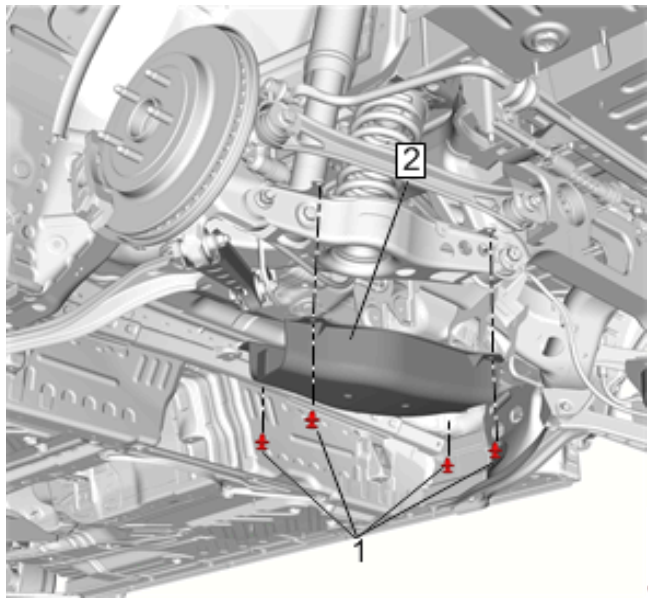

1. Remove the rear suspension lower control arm cover push pins (1) [4x].
2. Rear Suspension Lower Control Arm Cover (2)» Remove
3. Support the rear suspension lower control arm.

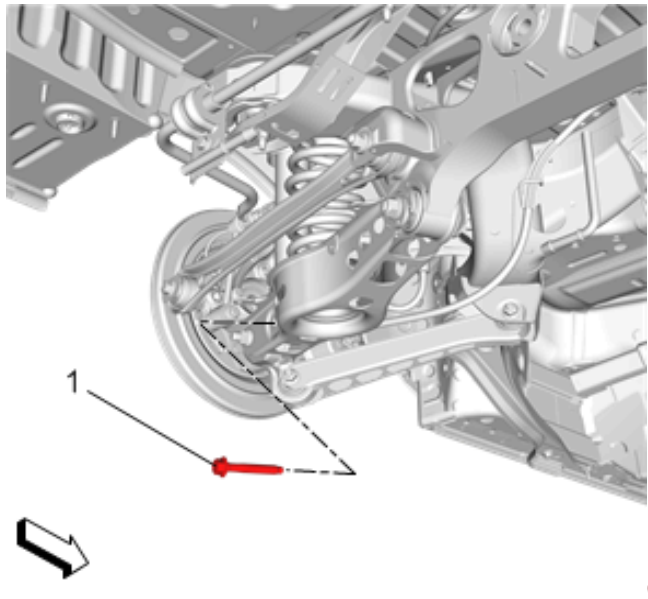

4. Rear Shock Absorber Bolt (1)» Remove and DISCARD

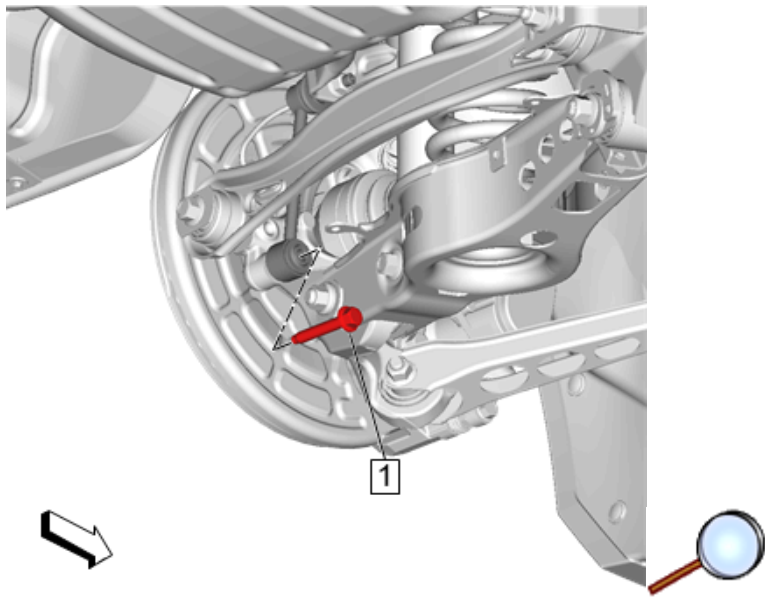

5. Stabilizer Shaft Link Bolt (1) » Remove

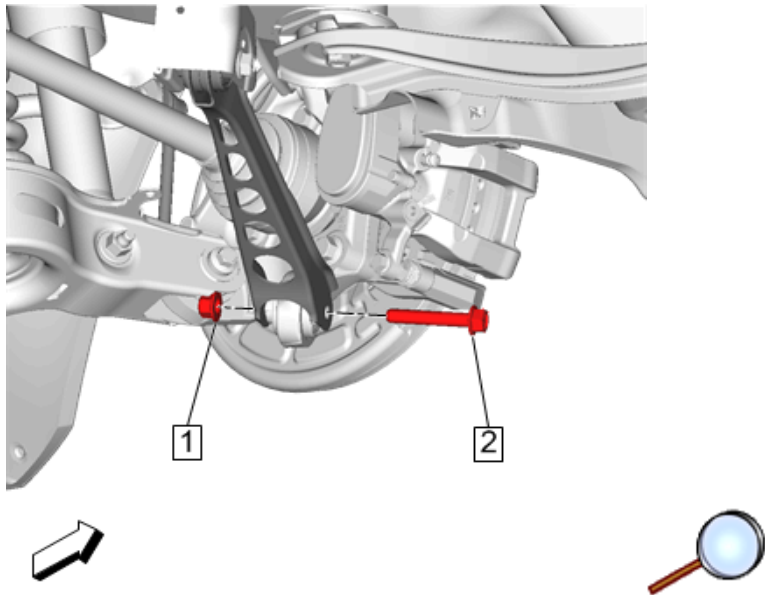

6. Rear Suspension Lower Trailing Link Outer Nut (1) » Remove

7. Rear Suspension Lower Trailing Link Outer Bolt (2) » Remove and DISCARD

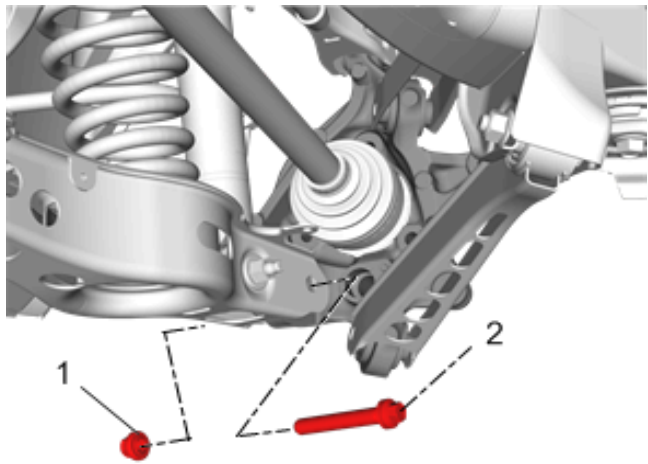

8. Remove the rear suspension lower control arm outer nut (1) and bolt (2).

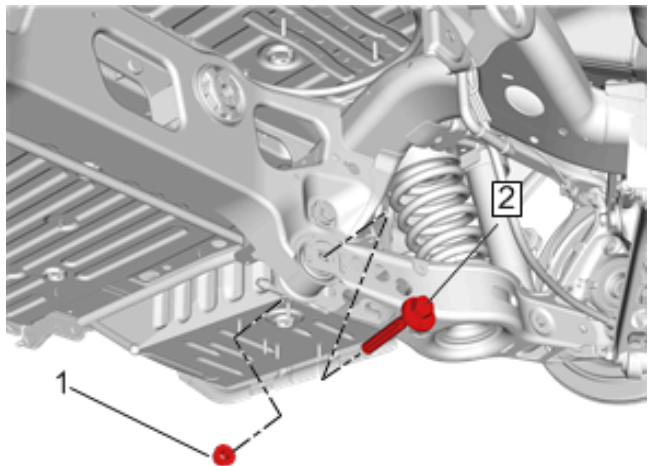

9. Remove the rear suspension lower control arm inner nut (1) and bolt (2).

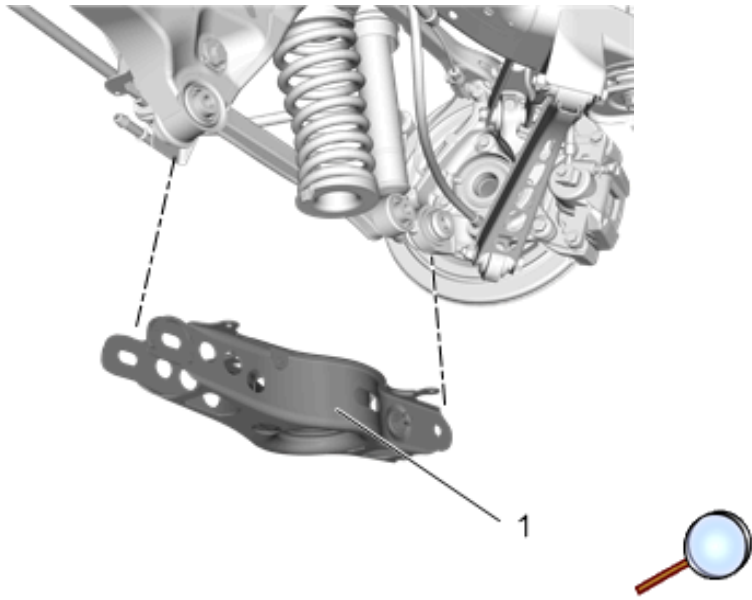

**Caution:** Pry bar tools may cause damage to the ball joint seals when removing links from the knuckle. Damage to the seals may cause knuckle and control arm failure. The knuckle will need to be replaced if there is damage to the seals.

10. Rear Suspension Lower Control Arm (1)» Remove
11. Install new spring

### Installation Procedure

**Caution:** Refer to [Fastener Caution](#).

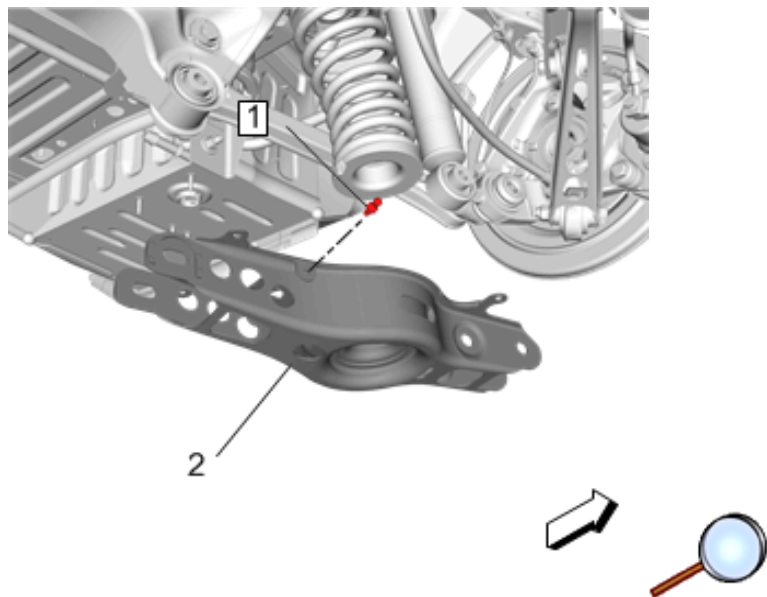

1. Rear Suspension Lower Control Arm (1)» Install

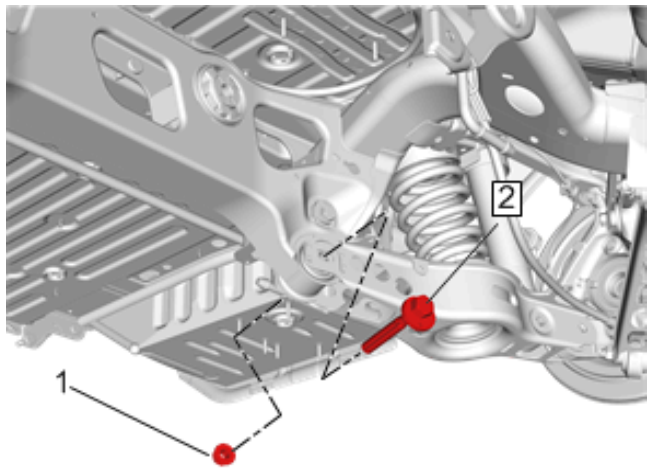

2. Install the rear suspension lower control arm inner nut (1) and bolt (2). Do not tighten at this time.

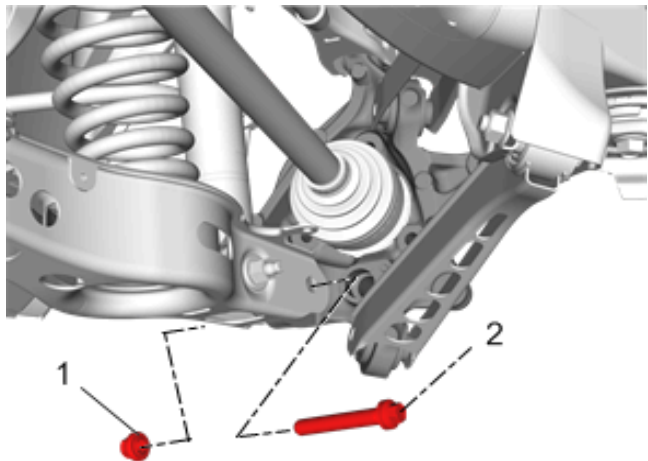

3. Rear Suspension Lower Control Arm Bolt (2) » Install

4. Rear Suspension Lower Control Arm Nut (1) » Install

**Note:** Tighten the bolt and hold the nut.

**Tighten**

First Pass: **150N•m (111 lb ft)**

Final Pass: **plus 90-105 degrees**

5. Rear Suspension Lower Control Arm Inner Nut » Tighten

**Tighten**

First Pass: **115N•m (85 lb ft)**

Final Pass: **plus 90-105 degrees**

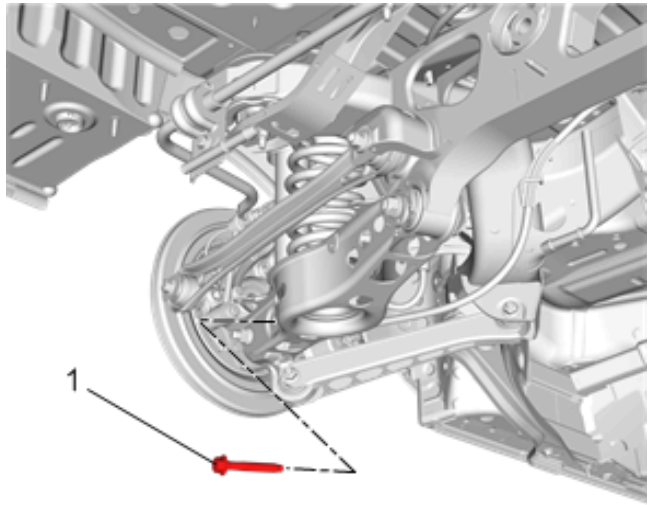

**Warning:** This vehicle is equipped with torque-to-yield or single use fasteners. Install a NEW torque-to-yield or single use fastener when installing this component. Failure to replace the torque-to-yield or single use fasteners could cause damage to the vehicle, component, or bodily injury.

6. Install the NEW rear shock absorber lower bolt (1).

**Tighten**

First Pass: **100N·m (74 lb ft)**

Final Pass: **plus 90-105 degrees**

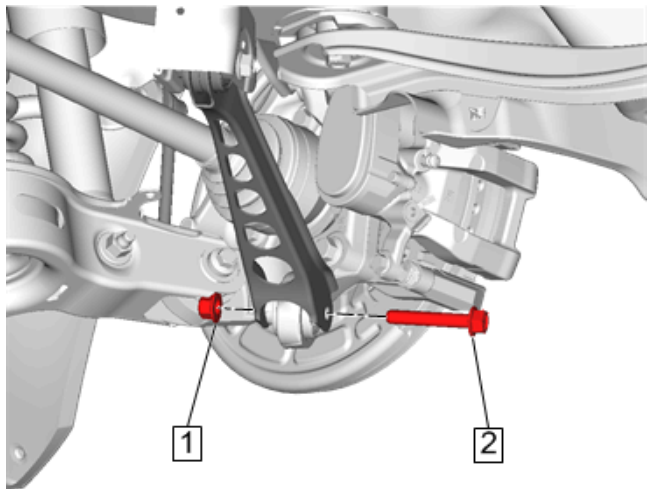

7. Rear Suspension Lower Trailing Link Outer Bolt (2) » Install a NEW bolt

8. Rear Suspension Lower Trailing Link Outer Nut (1) » Install

**Note:** Tighten the bolt and hold the nut.

**Tighten**

8.1. First Pass: **100N•m (74 lb ft)**

8.2. Final Pass: **plus 90–105 degrees**

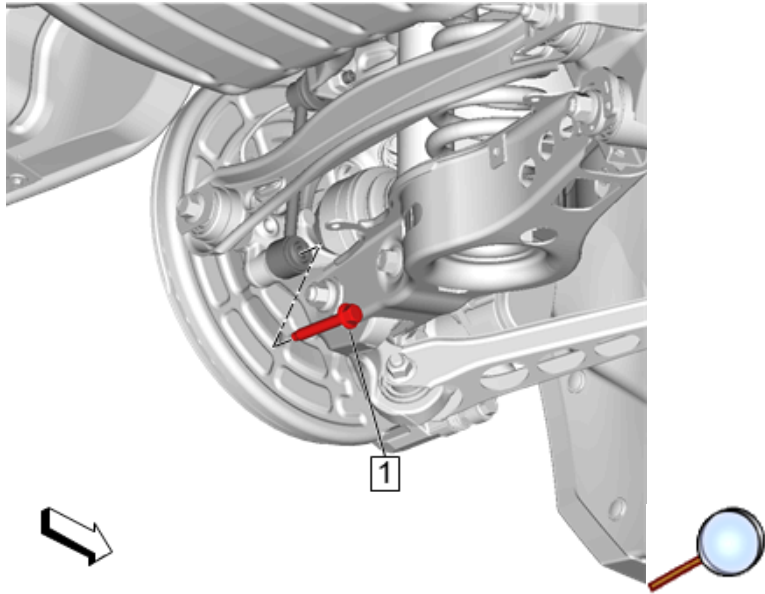

9. Stabilizer Shaft Link Bolt (1) » Install and tighten **58N•m (43 lb ft)**

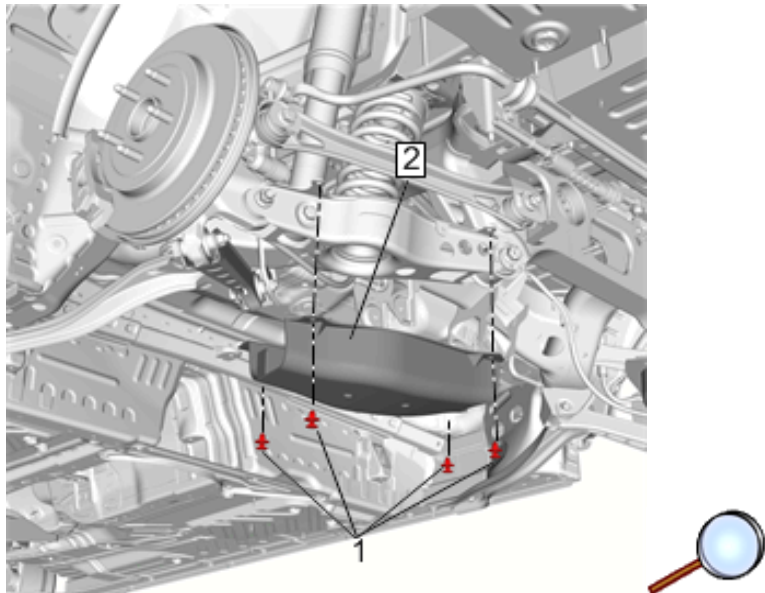

10. Rear Suspension Lower Control Arm Cover (2) » Install

11. Install the rear suspension lower control arm cover push pins (1) [4x].

12. Install the rear wheel. [Tire and Wheel Removal and Installation](#)

13. Remove the safety stands.

14. Lower the vehicle to the ground.

### **Vehicle Alignment**

After inspection of all suspension kit components, vehicle must be aligned to OEM specifications.