

Body Emblem Package Installation (Front Fascia)

Installation Instructions Part Number

23461744

Kit Contents

Qty	Description
1	Emblem Package Gold Bow tie – Body (P/N 23380120)
1	Emblem Assembly Gold Bow tie – Front Grille Illumination (P/N 23461746)
1	Harness Package – Accessory Wiring (P/N 23380118)
1	Harness Assembly – Accessory Wiring (P/N 23380115)
5	Tie Strap – Wiring Harness Attach (P/N 11509086)
1	Installation Instructions
OR	
1	Emblem Package Black Bow tie – Body
1	Emblem Assembly Black Bow tie – Front Grille Illumination (P/N 233693029)
1	Emblem Assembly Gold Bow tie – Rear Compartment Illumination (P/N 23358106)
1	Harness Package – Accessory Wiring
1	Harness Package – Accessory Wiring
5	Tie Strap – Wiring Harness Attach (P/N 11509086)
1	Solvent Package
1	Installation Instructions

Required / Recommended Tools

Drill Motor

1 3/4" Hole Saw

Heat Gun

Procedure

1. Read all instructions before performing procedure.
2. Inspect kit to verify all parts are included.
3. Turn off the vehicle.

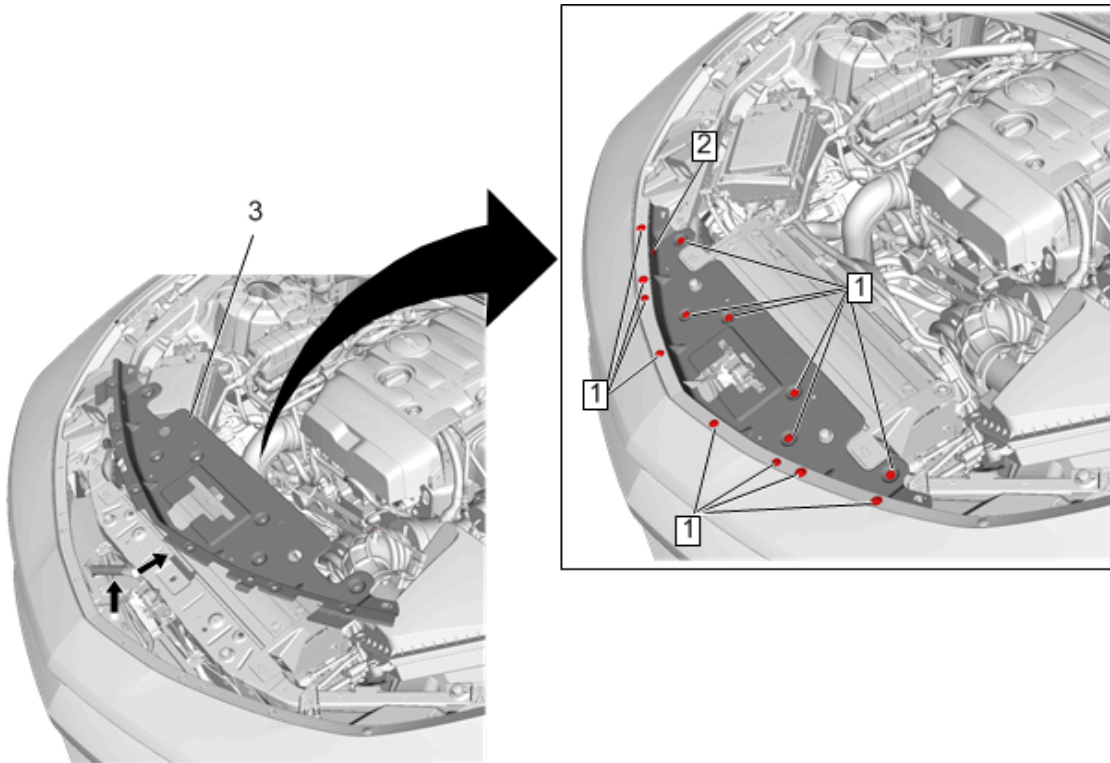

4. Remove the fasteners (1) and push retainer (2) in order to remove the front fascia upper support (3).
5. Remove the front fascia. Refer to Vehicle Service Manual.

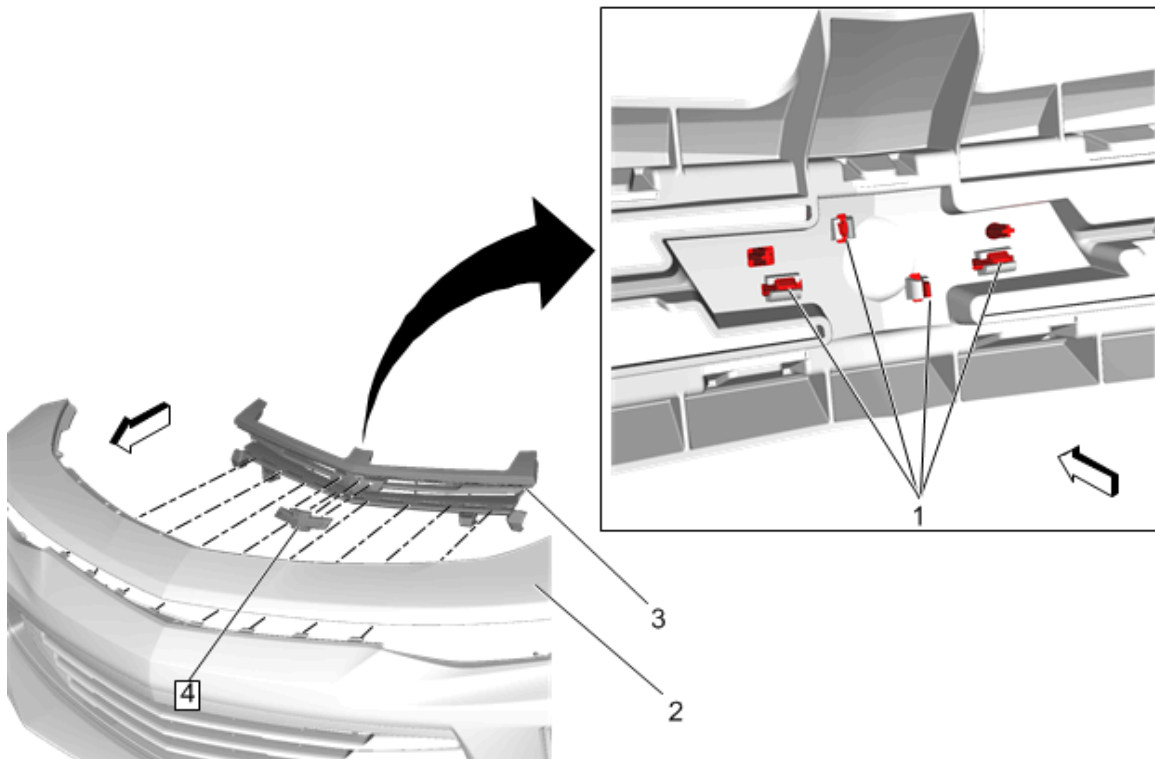

6. Remove the upper grille assembly (3) from the front fascia (2) then remove the front emblem (4) by disconnecting the retaining tabs (1) on the backside.

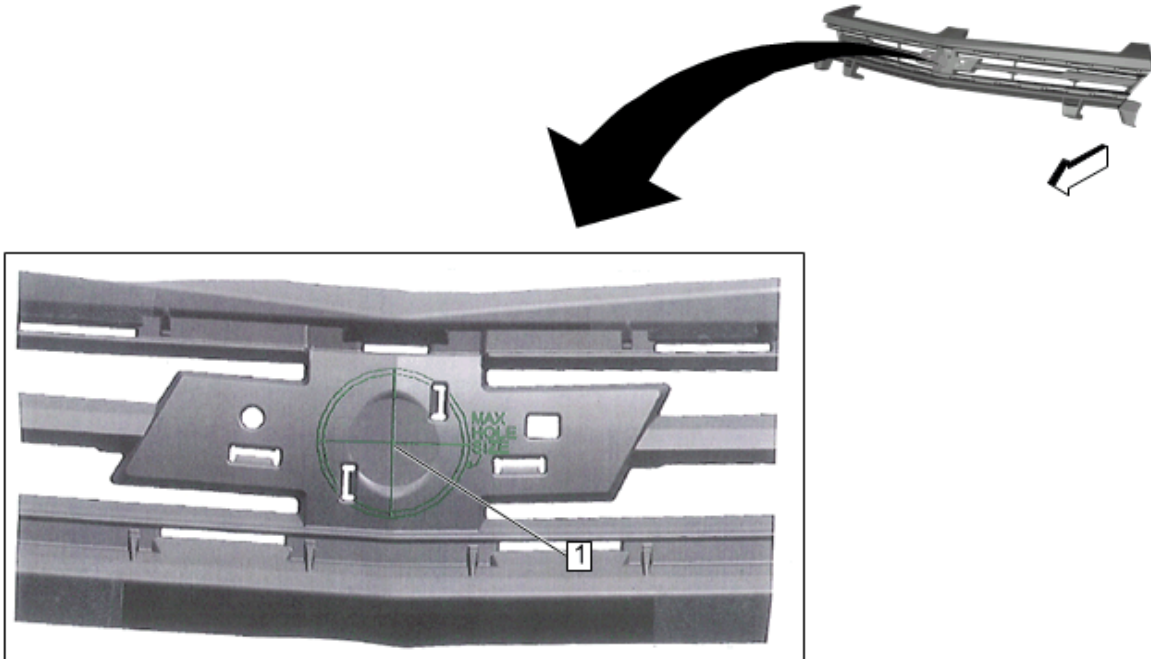

7. Drill/cut a 1 3/4" opening in the upper grille assembly using the scribe lines on the grille assembly as a guide. Center the hole with the cross-hair scribe line (1). Do not exceed the outer scribe line boundary.

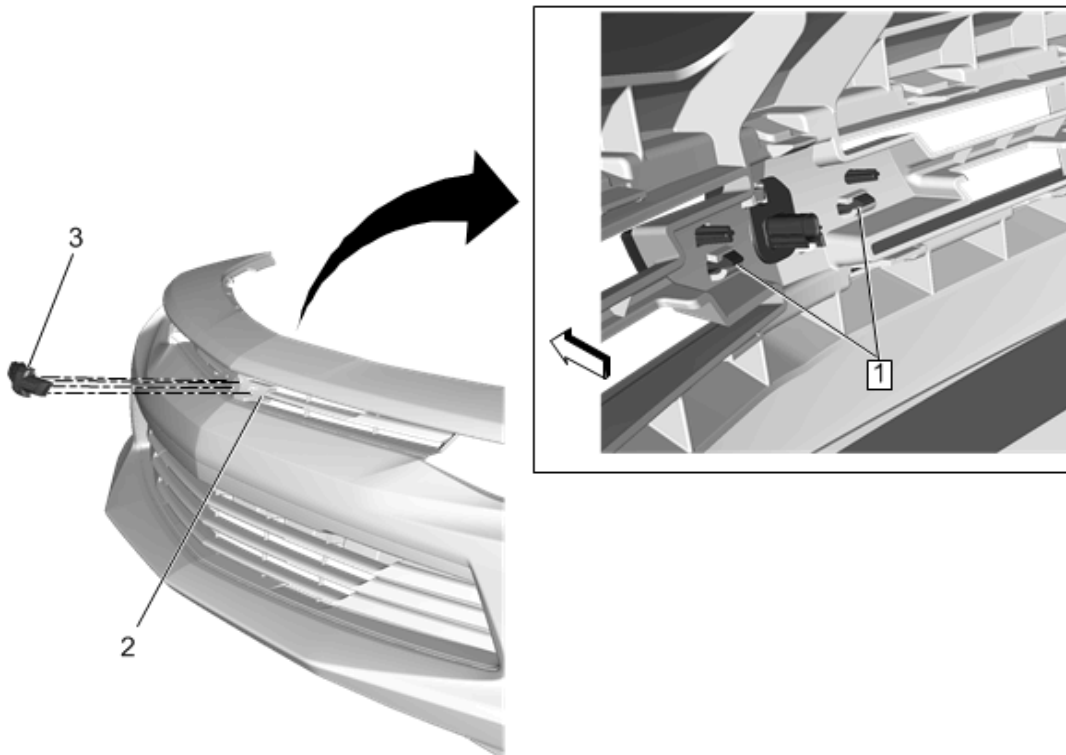

8. Install the illuminated emblem from kit (3) to the grille (2) by engaging the retaining tabs (1) on the backside.

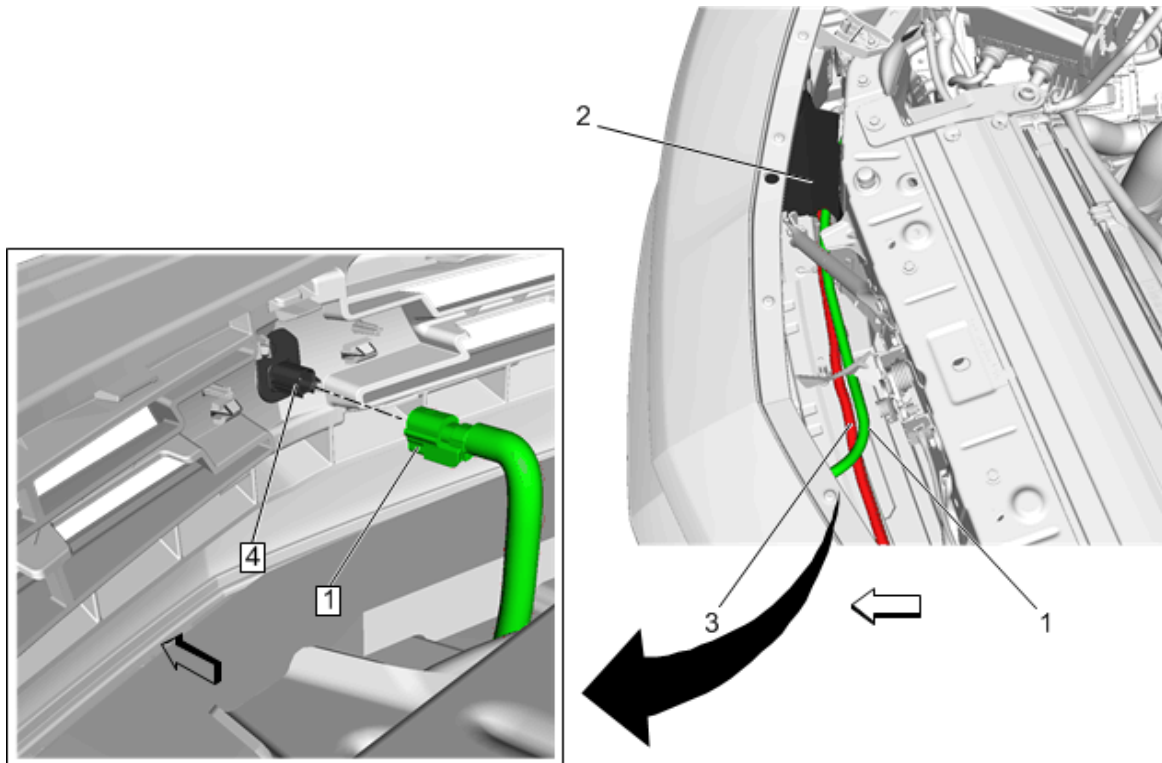

9. Obtain harness package from kit and route single connector end of harness assembly (1) P/N 23380115 from kit through hole in baffle assembly (2) adjacent to forward lamp harness on the passenger side of the vehicle.

10. Attach jumper connector (1) to the illuminated emblem (4).

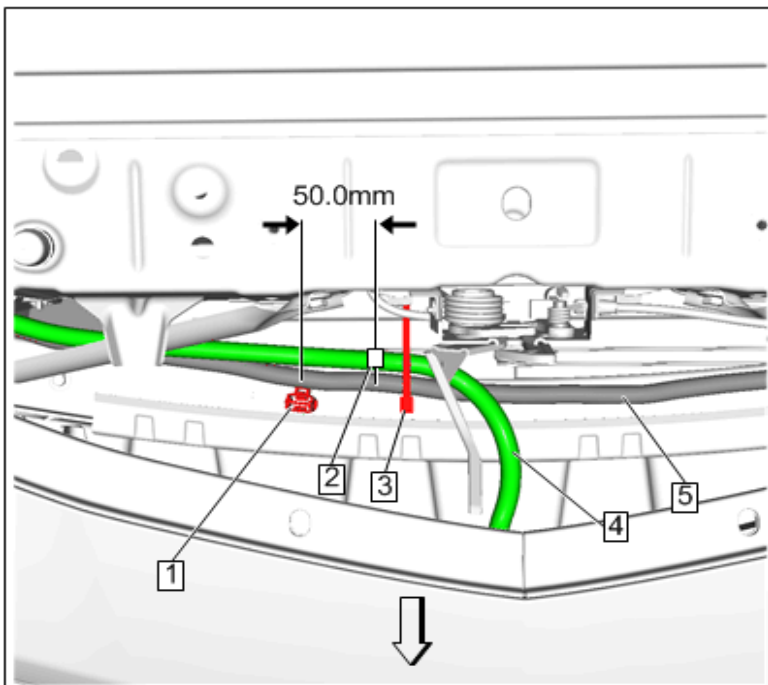

11. Align marker tape (2) on jumper harness 50.0mm from forward lamp harness clip (1) and secure jumper harness (4) to forward lamp harness (5) with tie strap (3) provided in kit.

12. Install the front fascia. Refer to Vehicle Service Manual.

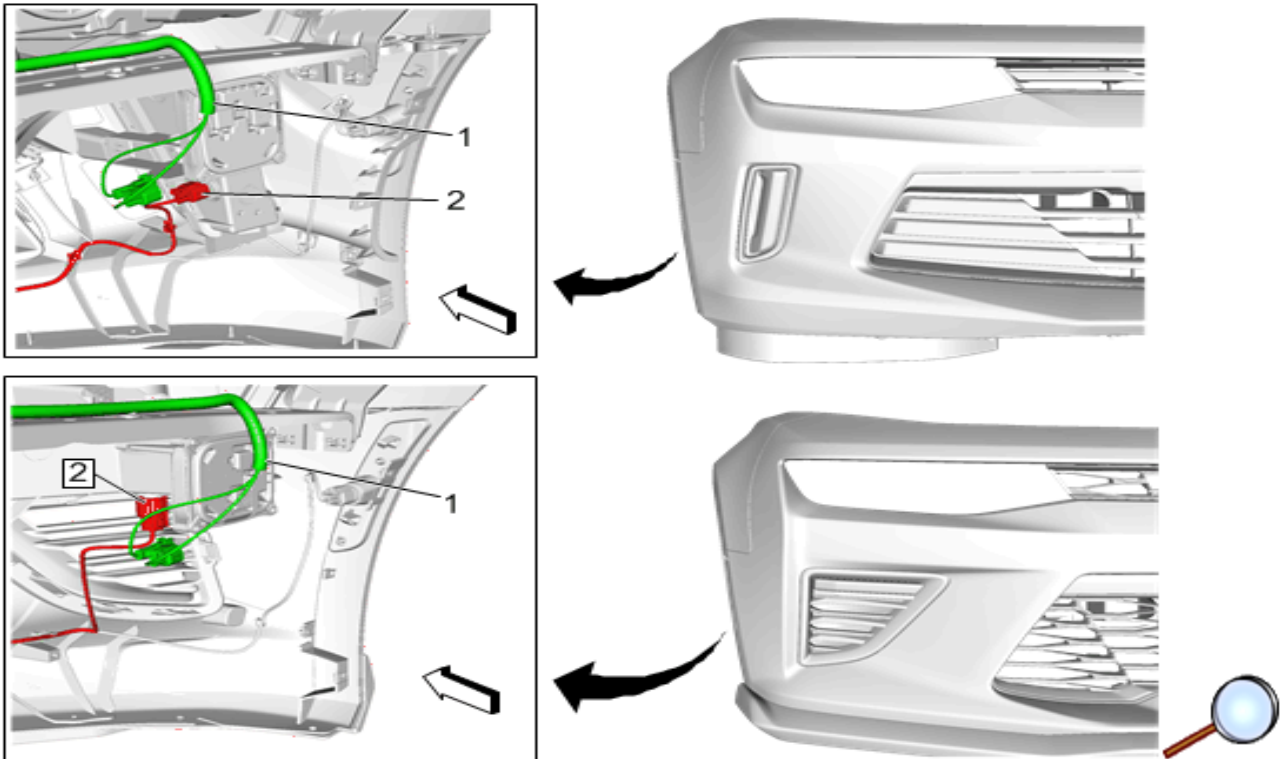

13. Refer to graphic above for correct DRL front fascia configuration.

Continue routing jumper harness (1) until dual connector end reaches front fascia harness connector (2).

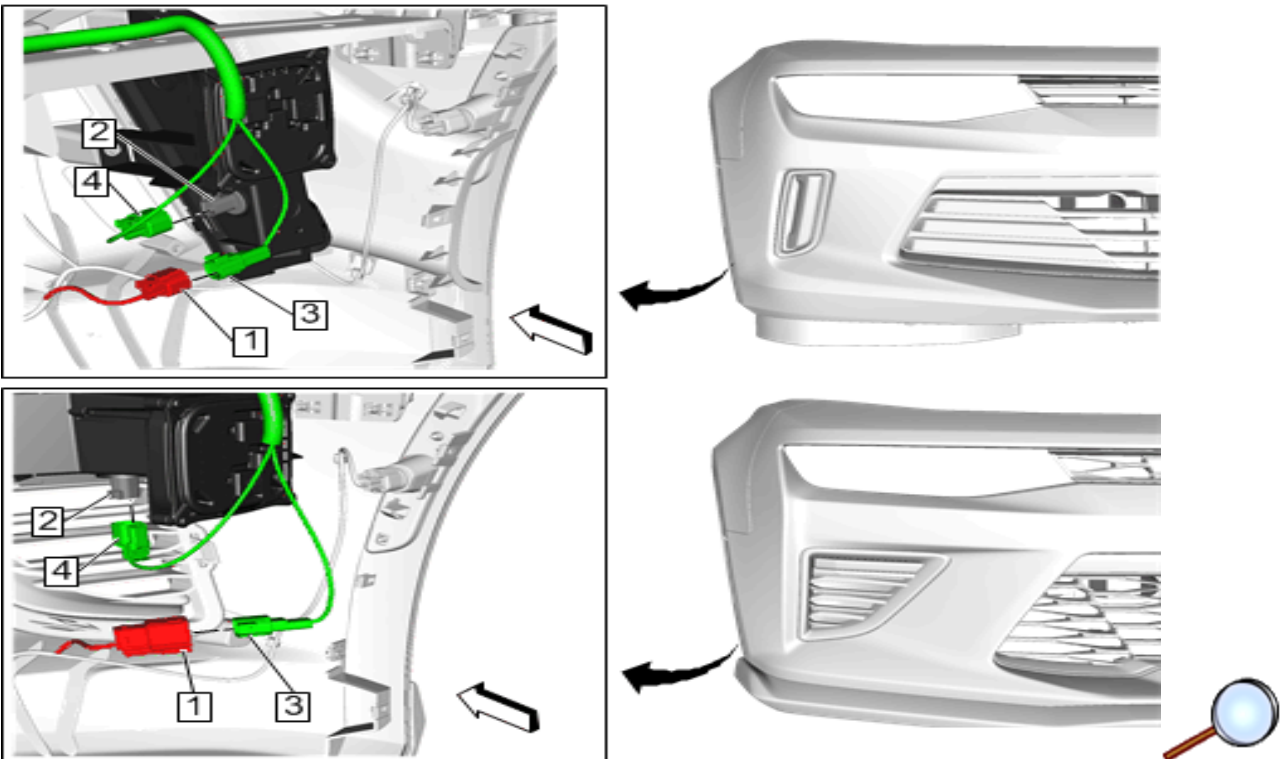

14. Refer to graphic above for correct DRL front fascia configuration.

Disconnect front fascia harness connector (1) from RH DRL Lamp (2).

15. Connect front fascia harness connector (1) into mating end of jumper harness connector (3).

16. Connect other end of jumper harness connector (4) into RH DRL Lamp (2).

17. Secure jumper harness to forward lamp harness where feasible to avoid rattle.

18. Bezel light will illuminate when park lamps are active and when headlamps are ON.

19. If you are installing the illuminated gold bow tie kit, reinstall previously removed components, installation complete.
20. If you are installing the illuminated black bow tie kit, reinstall previously removed front components and proceed with the installation of the rear black bow tie.

Rear Bow Tie Emblem Replacement

1. Mark position of production emblem with a washable marker or masking tape prior to removal.
2. Use a heat gun or equivalent to remove the emblem from painted sheet metal surface. Carefully use a plastic flat bladed tool to assist in removal.
3. Clean any remaining residue with included solvent wipe or with a 50/50 mixture by volume of isopropyl alcohol and clean drinkable water. Wipe surface dry with a clean lint free towel.
4. When removing protective liners from the adhesive tape, be careful no to touch tape with hands and do not allow tape to come in contact with dirt or any foreign matter prior to adhesion.
5. Position new black emblem carefully within reference marks and place on prepared surface.
6. Using the palm of the hand, wet out the emblem to ensure full adhesion is achieved.