

YMMS: 2017 Chevrolet Camaro ZL1
 Engine: 6.2L Eng
 VIN:

Sep 14, 2021
 License:
 Odometer:

ENGINE PERFORMANCE > 6.2L VIN 6

Fig 1: 6.2L VIN 6, Engine Performance Circuit (1 of 9)

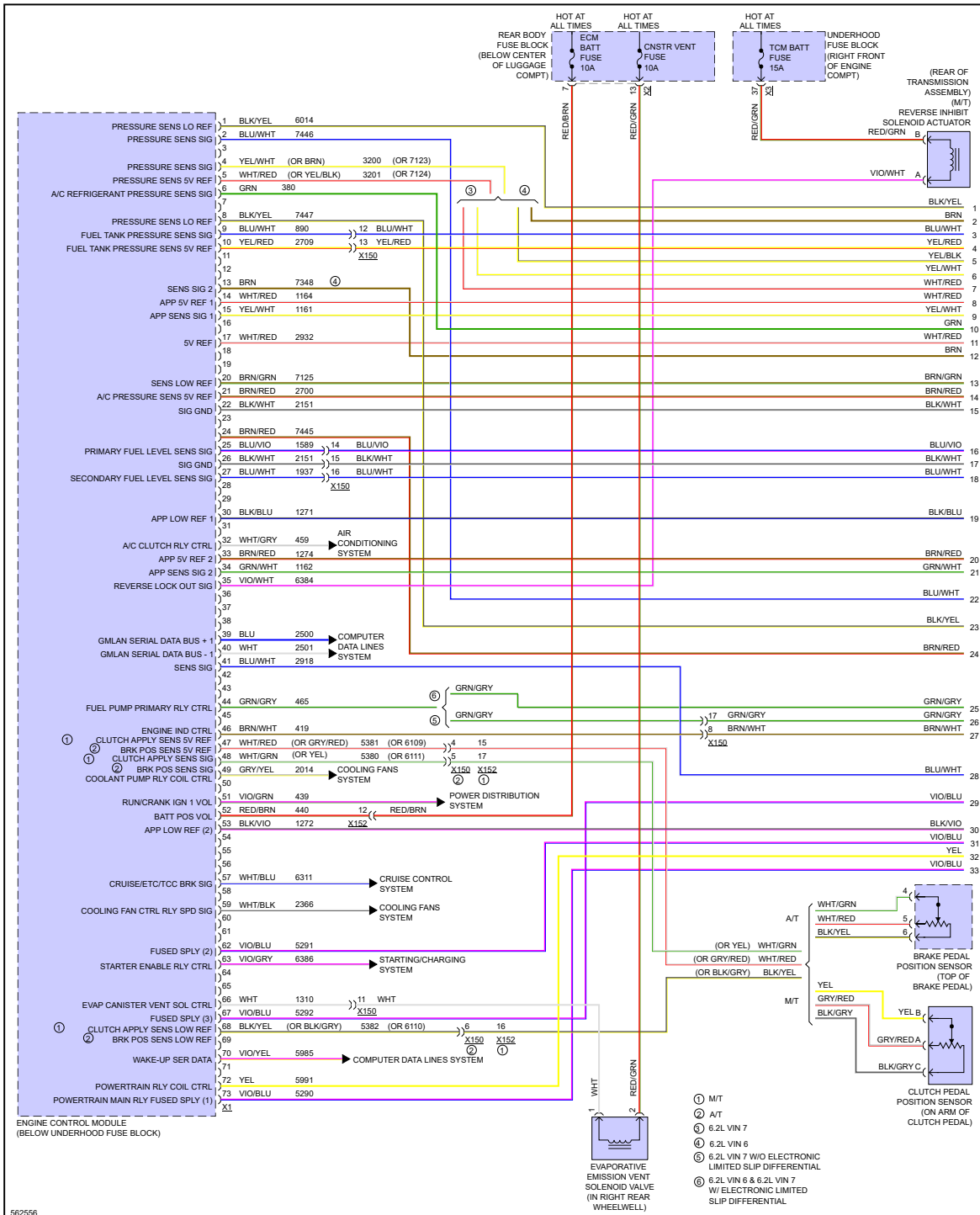

Fig 2: 6.2L VIN 6, Engine Performance Circuit (2 of 9)

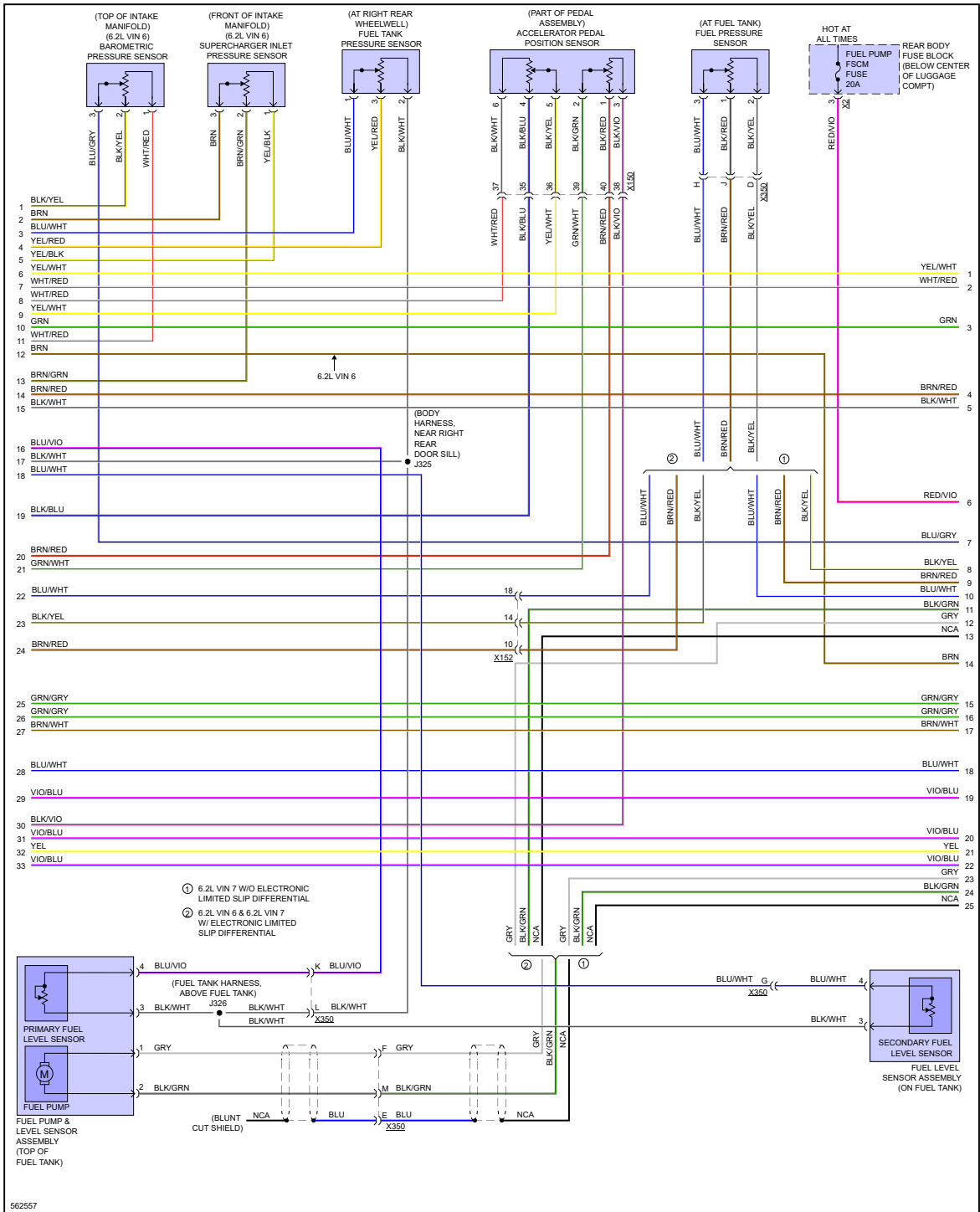
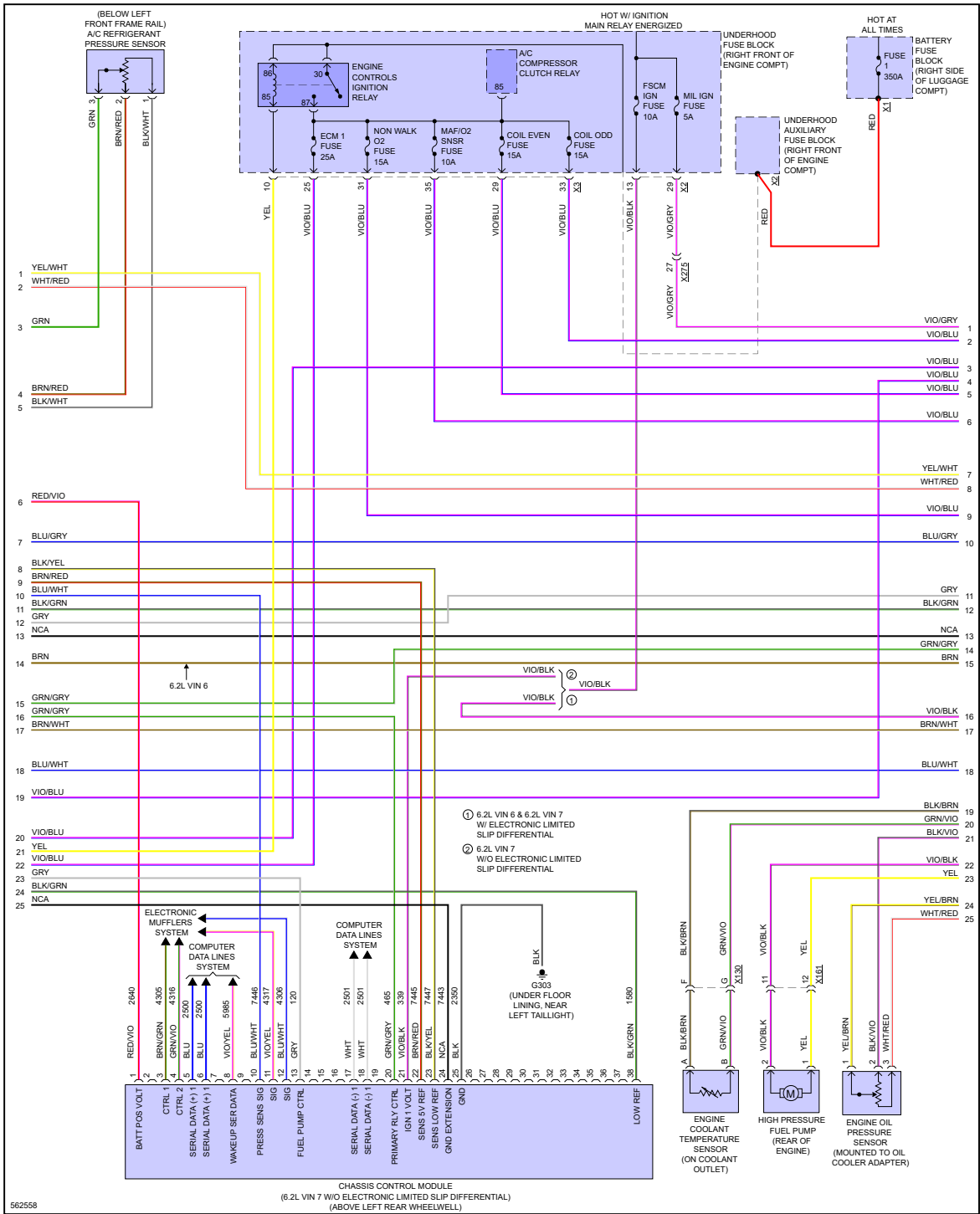

Fig 3: 6.2L VIN 6, Engine Performance Circuit (3 of 9)



562558

Fig 4: 6.2L VIN 6, Engine Performance Circuit (4 of 9)

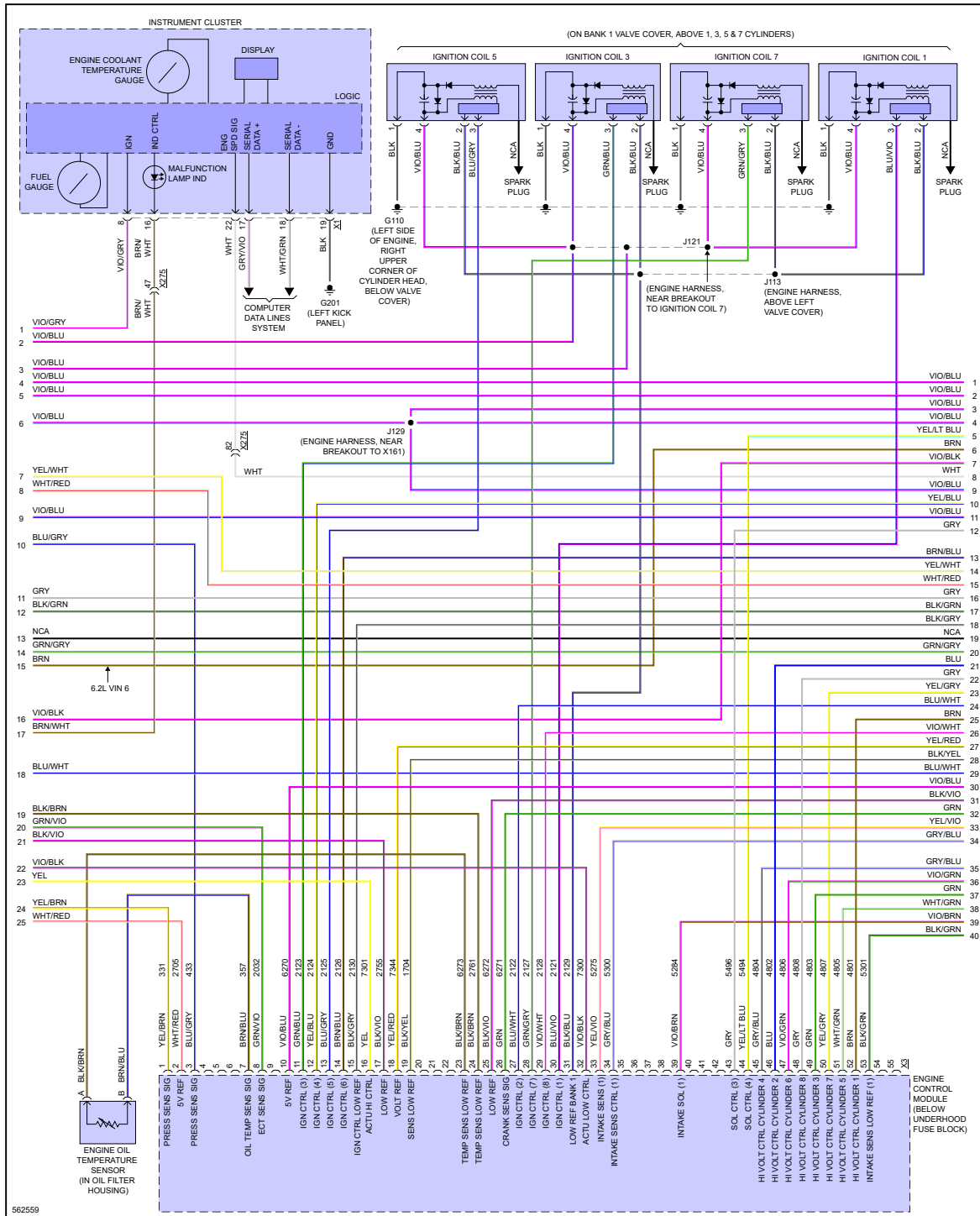

Fig 5: 6.2L VIN 6, Engine Performance Circuit (5 of 9)

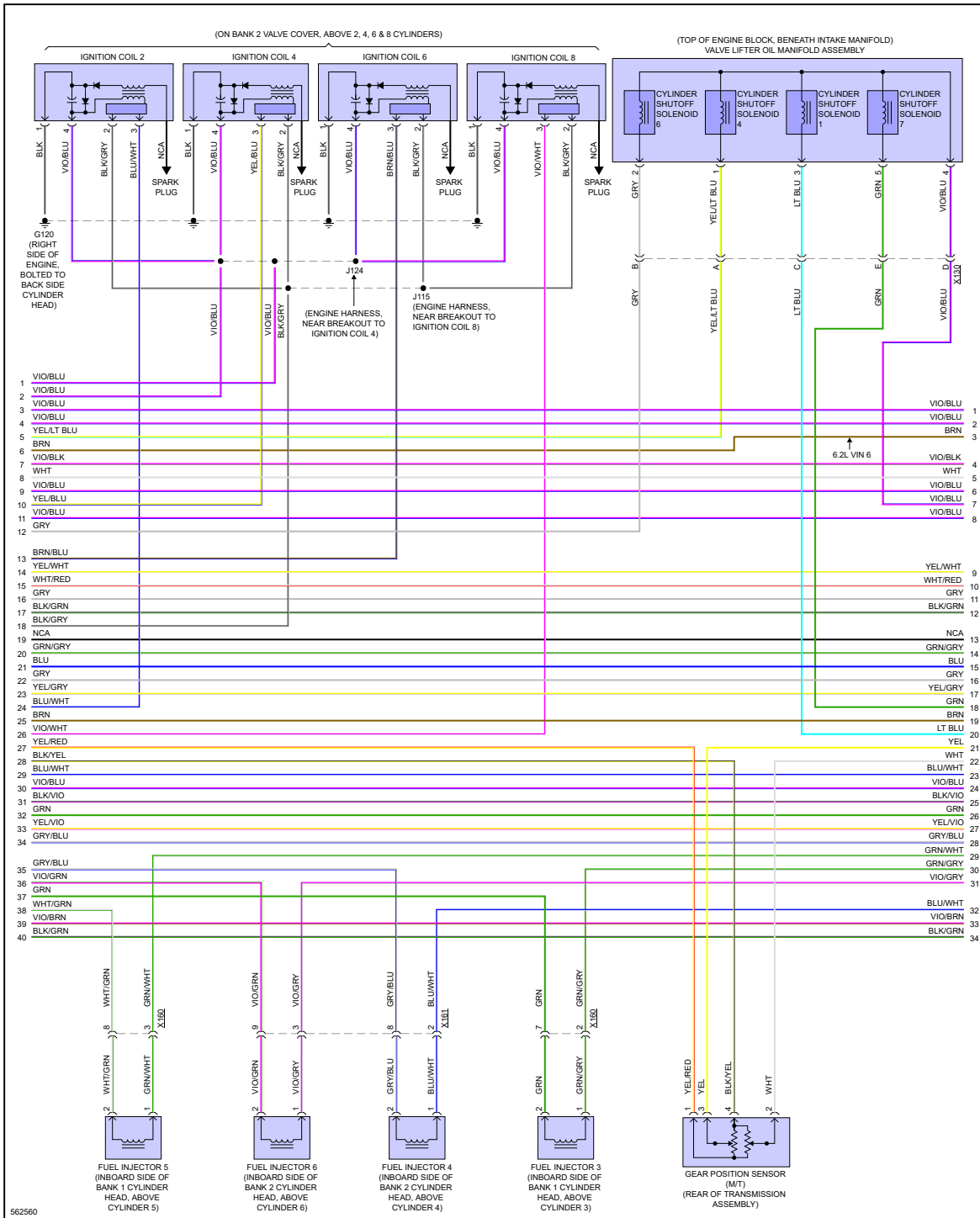
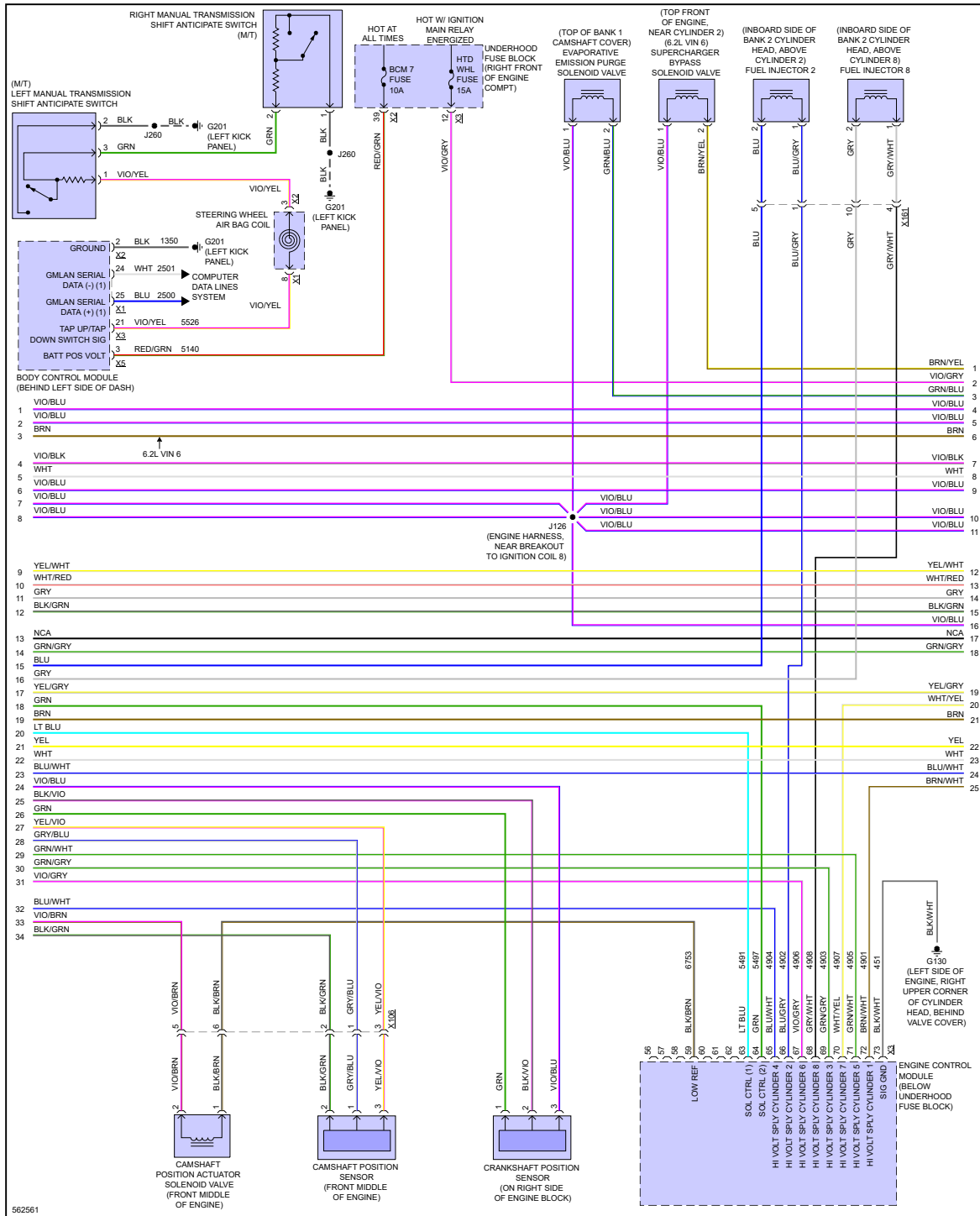

Fig 6: 6.2L VIN 6, Engine Performance Circuit (6 of 9)



562561

Fig 7: 6.2L VIN 6, Engine Performance Circuit (7 of 9)

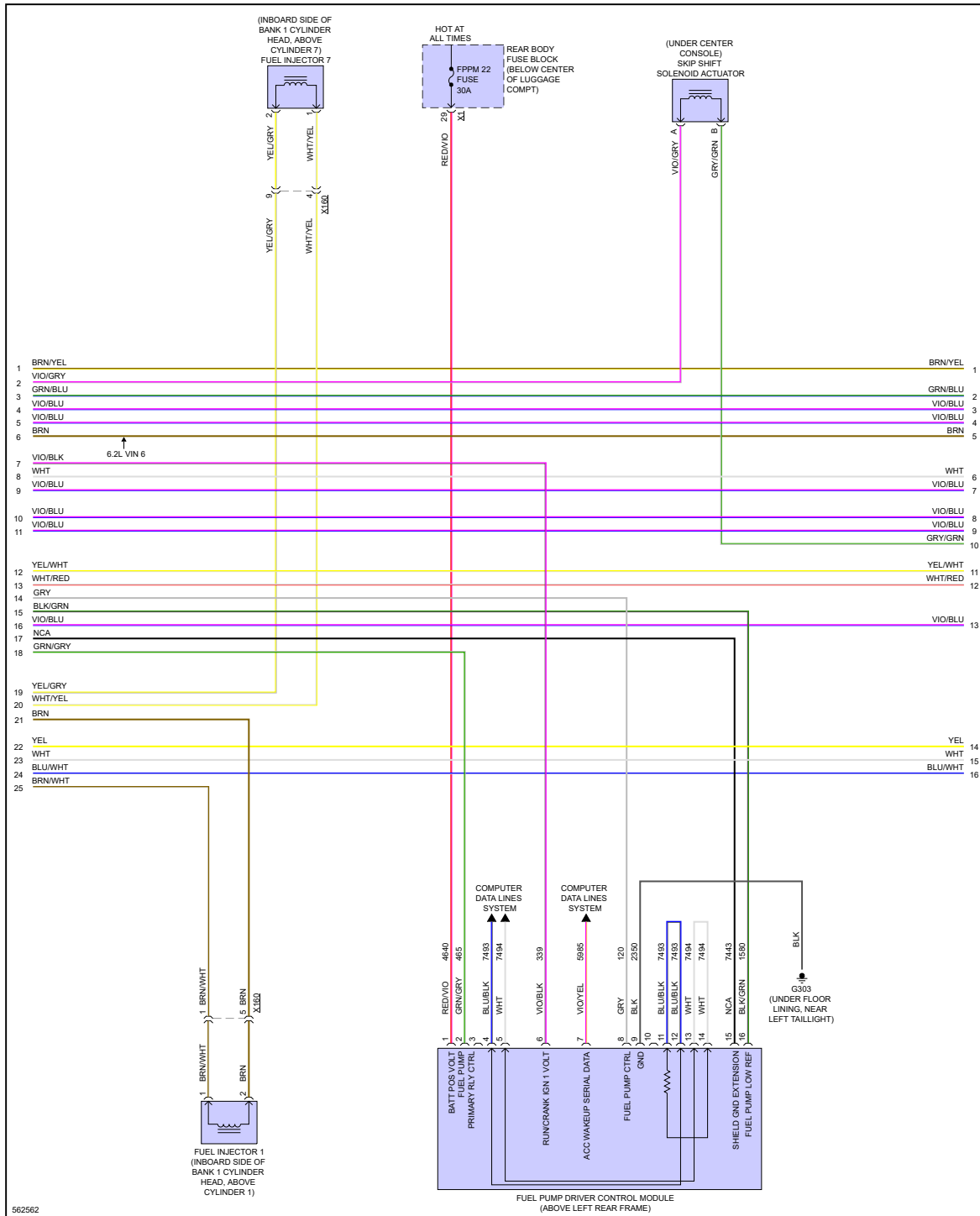

Fig 8: 6.2L VIN 6, Engine Performance Circuit (8 of 9)

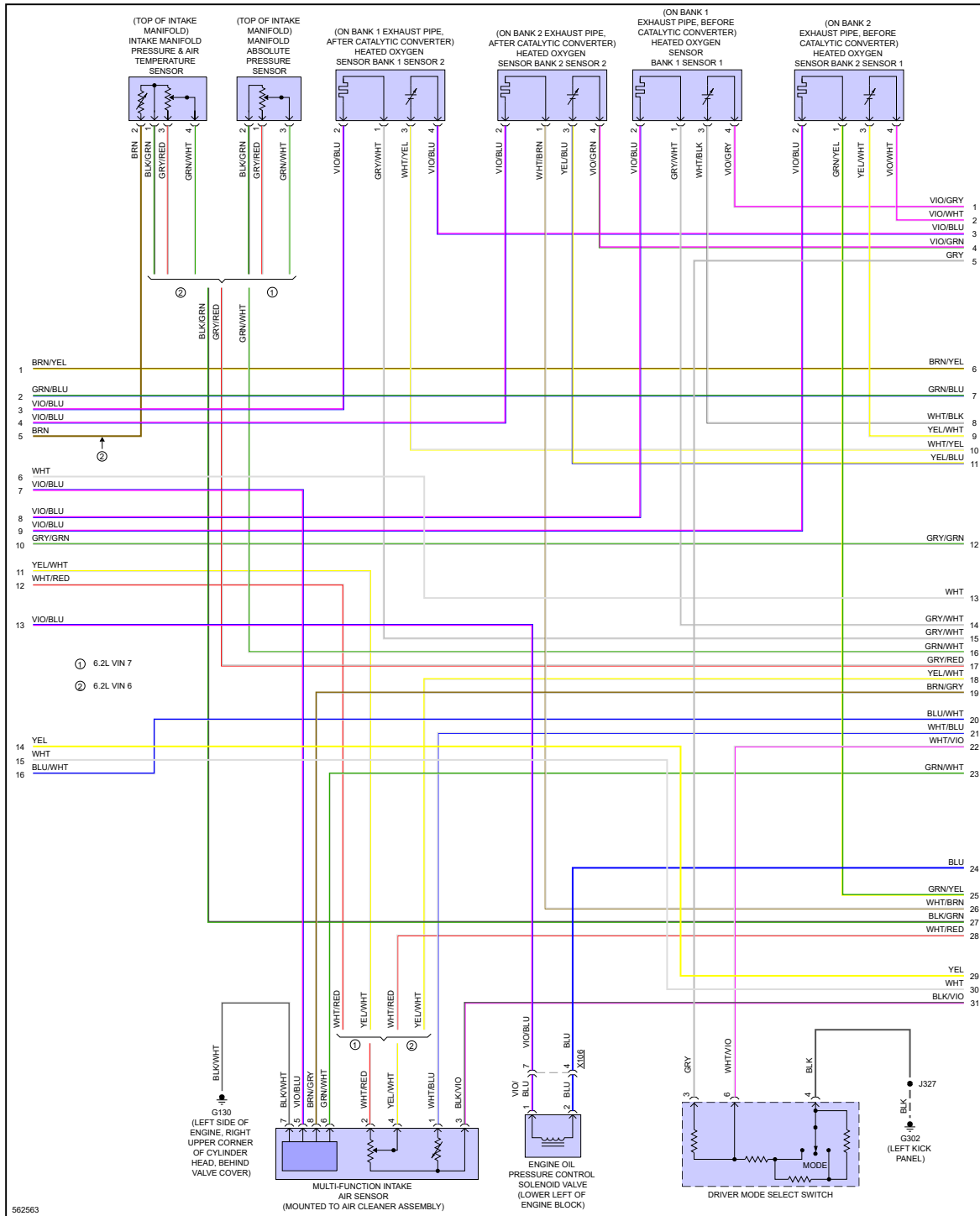

Fig 9: 6.2L VIN 6, Engine Performance Circuit (9 of 9)

