

Fig 18: Radio Circuit, W/ Navigation (2 of 5)

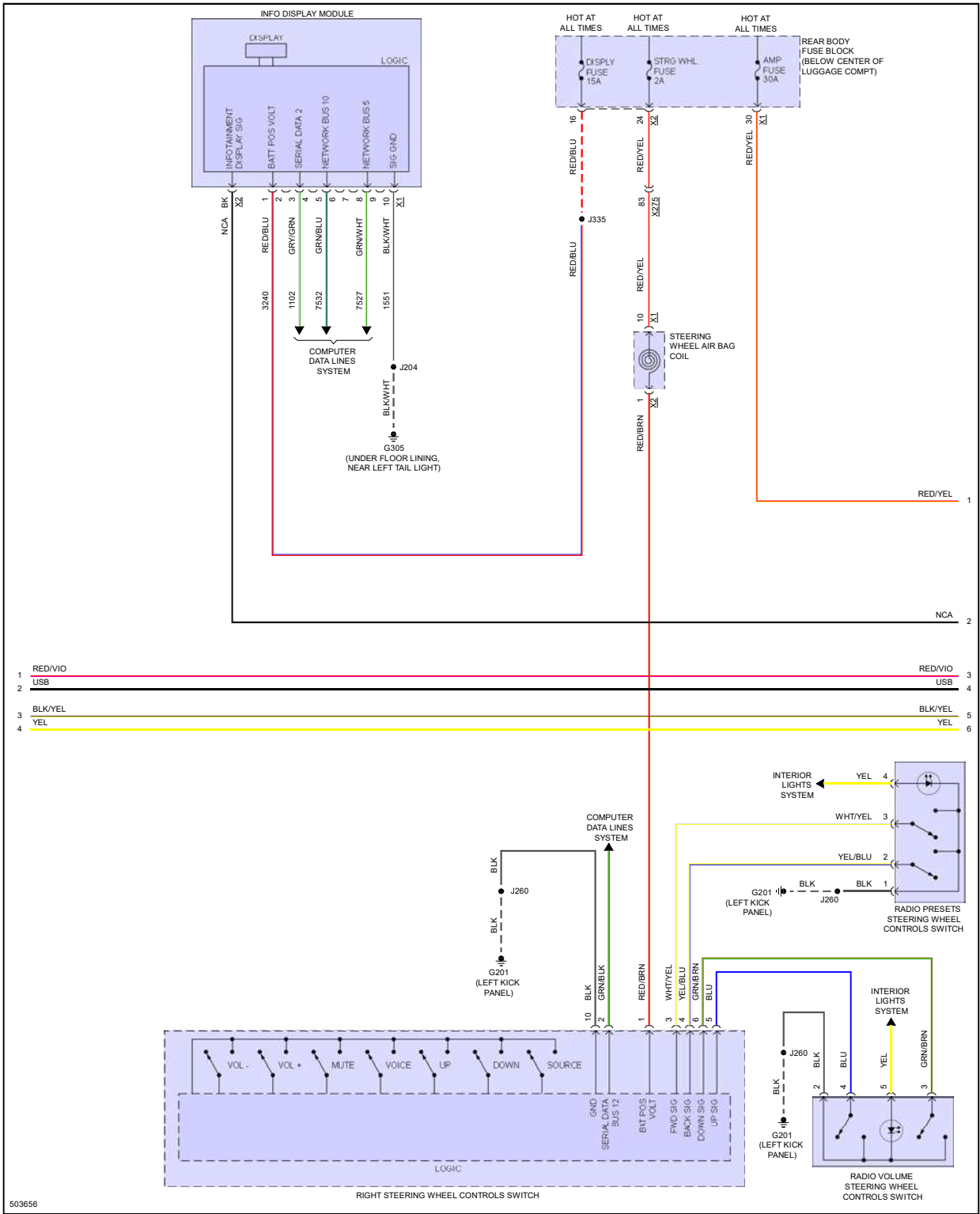

Fig 19: Radio Circuit, W/ Navigation (3 of 5)

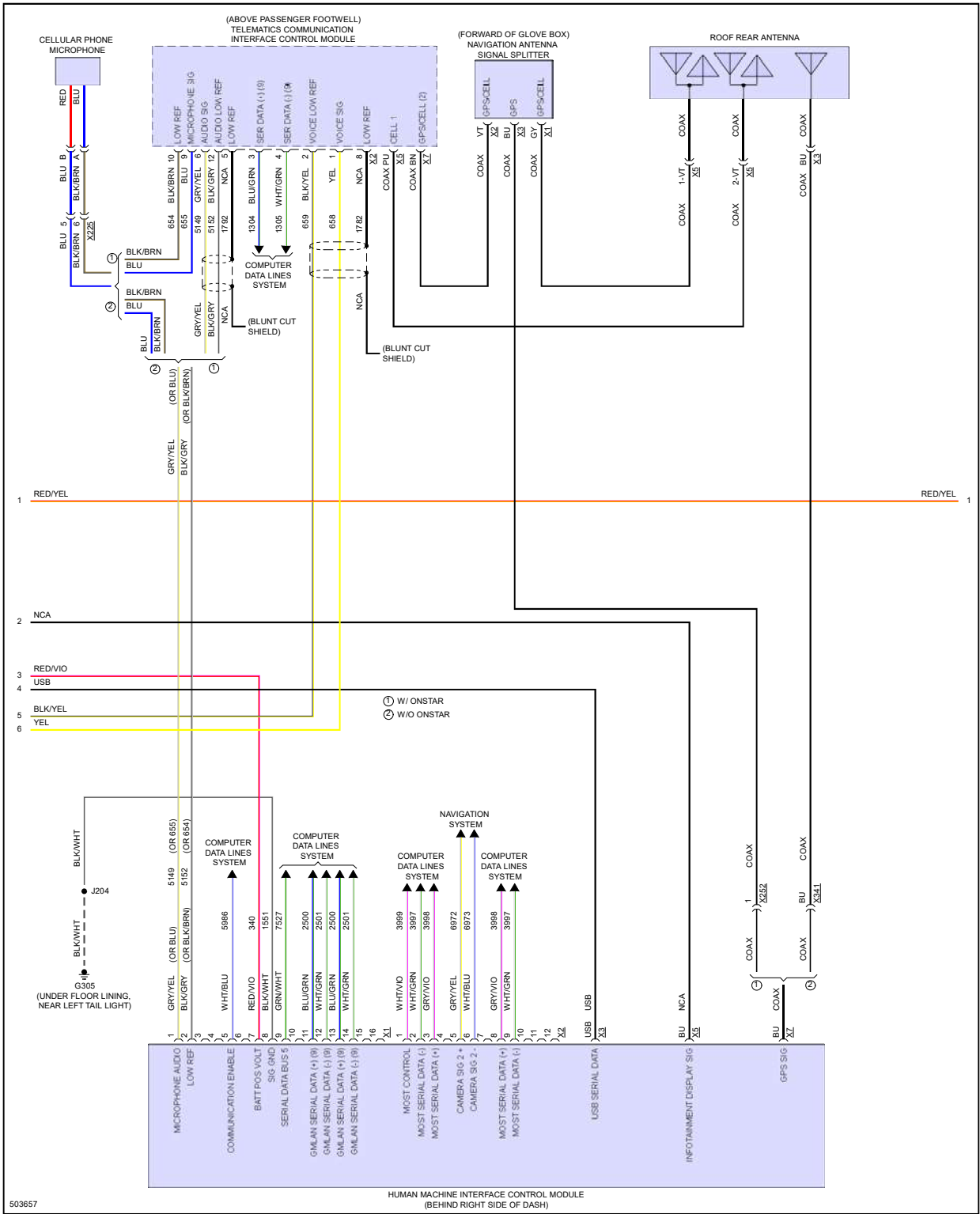

Fig 20: Radio Circuit, W/ Navigation (4 of 5)

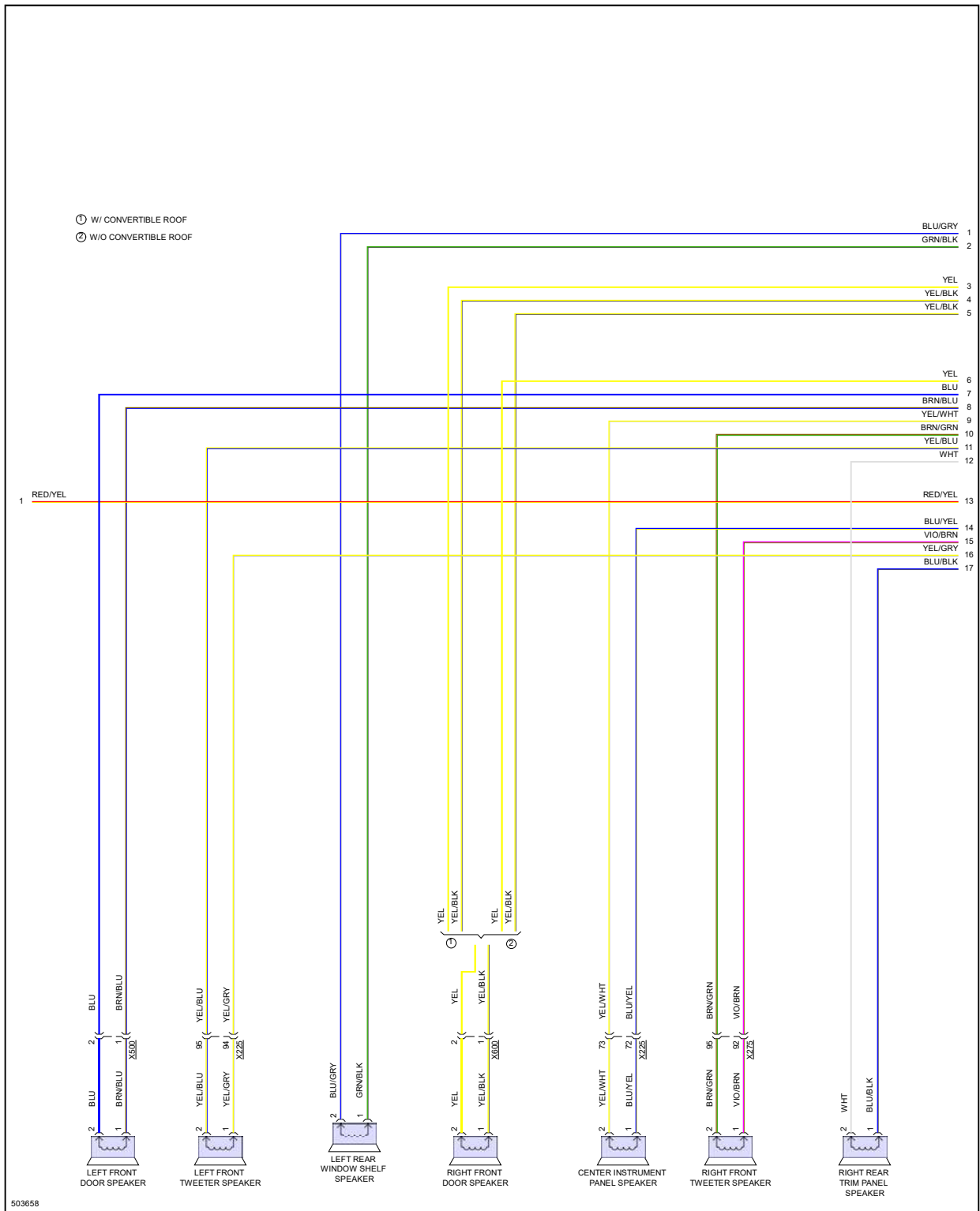
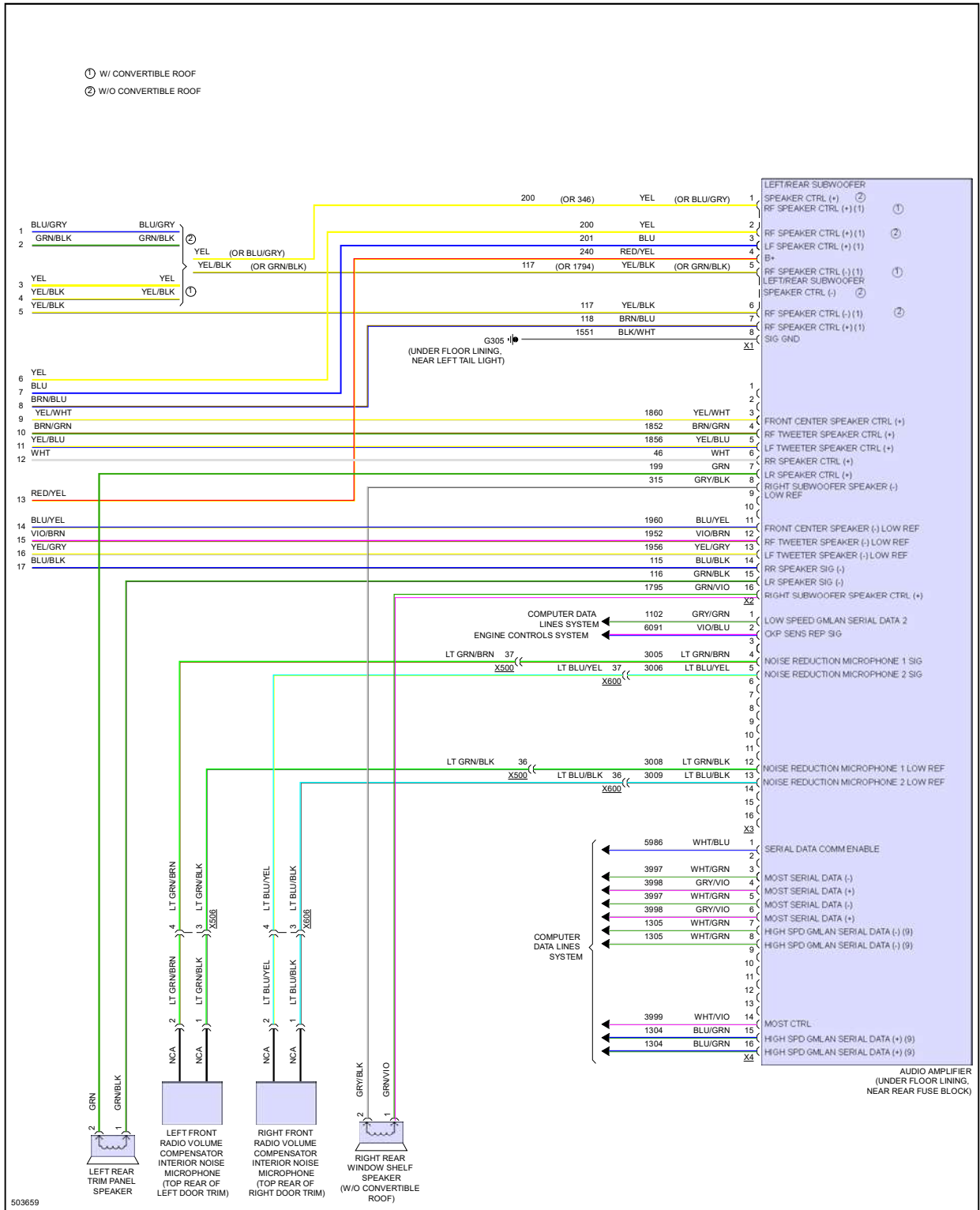

Fig 21: Radio Circuit, W/ Navigation (5 of 5)



SHIFT INTERLOCK

Fig 1: Park Brake System Circuit

