



SUPERCHARGER INSTALLATION MANUAL

LT4 ZL1 AND CTS-V



WHIPPLE SUPERCHARGERS

3292 NORTH WEBER AVE

FRESNO, CA 93722

TEL 559.442.1261

FAX 559.442.4153

www.whipplesuperchargers.com

*A color PDF of this manual is available, email
tech@whipplesuperchargers.com for a copy*

PREMIUM FUEL ONLY (91 OCTANE OR BETTER ALWAYS) RON+MON/2

CALIFORNIA AIR RESOURCE BOARD EXECUTIVE ORDER# D-231-48

*COMPETITION BASED PRODUCT MAY BE USED SOLELY ON VEHICLES USED IN SANCTIONED COMPETITION WHICH
MAY NEVER BE USED UPON A PUBLIC ROAD OR HIGHWAY*

INTRODUCTION

Before beginning installation, please read this manual and important notes:

- Please read the installation manual and verify that all items are present. If you are missing hardware or have any questions, please contact your dealer or Whipple Superchargers.
- Premium fuel (US 91 octane) is required to prevent spark-knock/detonation under certain operating conditions. Other countries must meet US 91 octane standards, RON+MON/2. If fuel of less than 91-octane is present in the vehicle fuel tank, the tank must be completely drained and refilled with 91 or higher octane to 1/8th of a tank.
- Operating your engine without the Whipple PCM recalibration can result in engine damage or failure and will void your warranty.
- Supply your stock calibration (along with gear ratio, transmission type, throttle body type and any changes to vehicle) to Whipple ahead of time so your unique PCM calibration can be built prior to the PCM being shipped or calibration emailed to minimize any down time.
- COMPETITION BASED PRODUCT MAY BE USED SOLELY ON VEHICLES USED IN SANCTIONED COMPETITION WHICH MAY NEVER BE USED UPON A PUBLIC ROAD OR HIGHWAY, UNLESS PERMITTED BY SPECIFIC REGULATORY EXEMPTION (VISIT THE "EMISSIONS" PAGE AT [HTTP://WWW.SEMASAN.COM/EMISSIONS](http://www.semasan.com/emissions) FOR STATE BY STATE DETAILS.
- COMPETITION BASED PRODUCT IS LEGAL IN CALIFORNIA ONLY FOR RACING VEHICLES WHICH MAY NEVER BE USED, OR REGISTERED OR LICENSED FOR USE, UPON A HIGHWAY.
- IT IS THE RESPONSIBILITY OF THE INSTALLER AND/OR USER OF THIS PRODUCT TO ENSURE THAT IT IS USED IN COMPLIANCE WITH ALL APPLICABLE LAWS AND REGULATIONS.

RECOMMENDED TOOLS AND SUPPLIES

The following items are not included in this supercharger kit and it is strongly recommended that they're used for ease of installation or maximum performance:

Torque Wrench

¼", 3/8" and ½" torque wrenches are required during installation.

Tools

Safety glasses, metric wrench set, ½" air ratchet, ¼", 3/8", ½" assorted metric socket set, 5mm ball head allen, 3/8" assorted metric allen socket set, 3/8" assorted torx socket set, 8mm hex allen wrench, ½" breaker bar, flat head screw driver and drain pan (for coolant). Crankshaft pulley puller and installer. Heat gun or small torch for heat shrinking. Electric tape. Trim pad tool (for pushpin removal).

Tie Straps

These will be useful for securing the wiring harness away from the installation area as directed in the instruction manual. They are inexpensive and will be very handy during installation. You will need an assortment of 4", 8" and 12".

Sealants

Thread sealant such as pipe Teflon must be used on all pipe threads. Ant-seize for bolt and spark plug threads (use only when stated, otherwise the torque value must be reduced).

Chemicals and lubricants

You will need some cleaner/degreaser such as carb cleaner, acetone. Assembly lubricant (white lithium grease or petroleum jelly). Loctite #243 thread locker.

You'll be required to fill your intercooler system with approx. 2 gallons of distilled water and GM Factory specification engine coolant. This is not supplied in the system, you can find the coolant at any local auto parts store. NEVER USE TAP WATER, as it can corrode and create poor performance.

Clean Shop Towels

Use these to keep the installation area clean.

PRE-INSTALLATION CHECKLIST

Before installing your Whipple Supercharger Kit, complete the following checklist.

1. Verify Condition of Vehicle: Before the supercharger kit is installed, ensure the engine runs smoothly and that the factory malfunction indicator light (MIL) is off. Only install the supercharger kit if the engine runs smoothly *and* the MIL is off.
2. **!! CAUTION !!** This product is intended for use only on STOCK, UNMODIFIED, WELL-MAINTAINED engines. Installation on a worn-out or modified engine is not recommended without factory computer and fuel system modifications. Custom engine configurations could require custom tuning and other supporting modifications.
3. Verify Fuel System: Supercharger systems should only be installed on vehicles that have new or clean fuel filters.
4. Assess Cleanliness of Installation Area: Make sure your work area and the under-hood area are free from debris. This supercharger is a high-quality, close-tolerance compressor and must not be subjected to contamination by dirt or any type of foreign material. If necessary, vacuum around engine to remove any foreign material.
5. **!! CAUTION !!** DO NOT remove the protective seal on the supercharger prior to installation. Foreign material entering the supercharger will automatically void all warranties.
6. Identify Supercharger Kit Components: Before beginning installation, identify all the components of your Whipple Supercharger Kit and ensure all items are present and undamaged.
7. **!! CAUTION !!** Do not attempt to start the engine before adding the supplied Supercharger Oil to the supercharger!

SAFETY PRECAUTIONS



CAREFULLY READ THE IMPORTANT SAFETY PRECAUTIONS AND WARNINGS BEFORE PROCEEDING WITH THE INSTALLATION!

Appropriate disassembly, assembly methods and procedures are essential to ensure the personal safety of the individual performing the kit installation. Improper installation due to the failure to correctly follow these instructions could cause personally injury or death. Read each step of the installation manual carefully before starting the installation.

- Always wear safety glasses for eye protection.
- Place the ignition switch in the off position.
- Always apply the parking brake when working on vehicle.
- Block the front and rear tire surfaces to prevent unexpected vehicle movement.
- Operate the engine only in well-ventilated areas to avoid exposure to carbon monoxide.
- Do not smoke or use flammable items near or around fuel system.
- Use chemicals and cleaners only in well-ventilated areas.
- Batteries can produce explosive hydrogen gas which can cause personal injury. Do not allow flames, sparks or flammable sources to come near the battery.
- Keep hands and any other objects away from the radiator fan blades.
- Keep yourself and your clothing away from moving parts when the engine is running.
- Do not wear loose clothing or jewelry that can be caught in rotating or moving parts.

GLOSSARY OF TERMS

ABBREVIATION	DESCRIPTION
ACT	Air Charger Temperature
DTC	Diagnostic Trouble Code
ECT	Engine Coolant Temperature
EGR	Exhaust Gas Recirculation
ETC	Electronic Throttle Control
EVAP	Evaporative emissions system
FHSCS	Flat Head Socket Cap Screw
HHFCS	Hex Head Flanged Cap Screw
IAT	Inlet Air Temperature
IC	Intercooler
ID	Internal Diameter
LB-IN	Pound-force inch
LB-FT	Pound-force foot
LTR	Low temp radiator
MAF	Mass Air Flow
MAP	Manifold Absolute Pressure
MY	Model Year
OBD	On Board Diagnostics
OD	Outside Diameter
PCV	Positive Crankcase Ventilation
PSI	Pound per Square Inch
SC	Supercharger
SHCS	Socket Head Cap Screw
TPS	Throttle Pressure Sensor
TRQ	Torque



****NOTICE:** Installation of Whipple Supercharger products signifies that you have read this document and have agreed to the terms stated within.

It's the purchaser's responsibility to follow all installation instruction guidelines and safety procedures supplied with the product as it's received by the purchaser to determine the compatibility of the product with the vehicle or the device the purchaser intends to install the product on.

Whipple Superchargers assumes no responsibility for damages occurring from accident, misuse, abuse, improper installation, improper operation, lack of reasonable care or all previously stated reasons resulting from incompatibility with other manufacturer's products.

There are no warranties expressed or implied for engine failure or damage to the vehicle in any way, loss of use or inconvenience or labor reimbursement. This includes merchantability and fitness.

The information contained in this publication was accurate and in effect at the time the publication was approved for printing and is subject to change without notice or liability. Whipple Superchargers reserves the right to revise the information presented herein or to discontinue the production of parts described at any time.

PRE-INSTALLATION INSPECTION WITH SCAN TOOL

1. It is advised to inspect the vehicle before install the supercharger kit as any potential problems can be found easier before the SC installation.
2. Carefully remove the supercharger system from its packaging and locate the flash device.
3. Connect the flash tool to the factory OBDII port, turn the ignition to "ON". Read the DTCs and data from the ADVANCED FEATURES prompt.
4. The car that you are installing the supercharger on should not have stored trouble codes. If the vehicle has a stored trouble code or has drivability problems, this should be addressed before SC installation.
5. The first data to be inspected is the LONG FUEL TRIMS. This data is a direct correlation of the air/fuel mixture. Perfect long fuel trims are 0 (this means the ECM is adding no fuel OR not subtracting fuel. In the REAL world the fuel trims -6 to +8 are considered to be correct).
6. With the engine warmed up at idle inspect long fuel trim Bank 1 (1,3,5,7) and long fuel trim Bank 2 (2,4,6,8), if the data is within -6 to +8 this is normal.
7. (Complete kits only) Make sure your battery is fully charged before installing, if not, install a battery charger to maintain 14volts. Kits not using the Whipple supplied tune are not 50-state legal and are for off-road use only.

SUPERCHARGER INSTALLATION INSTRUCTIONS

It is strongly recommended that you read through this guide **before** you begin installing the Whipple Supercharger.

1. (Complete kits) Using the supplied flash tool, connect to the factory OBDII connector.
 - Your computer must have a stock unaltered file or programmer will not load. If you have a modified PCM, return it back to stock to avoid any corruption issues. If your car has been tuned you will need to return it to stock before proceeding.
 - If you're unable to return it to stock you will need to take it to a GM dealer and have them update the computer.
 - Using the flash tool, install the Whipple supplied tune to the ECM/TCM before you continue. If you have any problems with your flash tool please call Whipple Superchargers: 559-442-1261 or email: tuning@whipplesuperchargers.com.
2. Using an air hose, blow off any loose dirt or debris from engine compartment. If really dirty, then steam clean the engine compartment before proceeding to the next step.
3. Locate the battery in the trunk by removing the access door on the passenger side. With an 8mm wrench disconnect the (-) negative battery cable. Make sure the cable is far enough away from the battery that it does not accidentally touch the battery and make connection during the installation.

4. Drain the coolant by removing the petcock on the lower driver side of the radiator. Remove the radiator cap to vent the system.
5. Disconnect the make-up air tube from the air inlet tube and catch can. Remove the factory air inlet tube and airbox lid from the engine (5/16" nut driver).

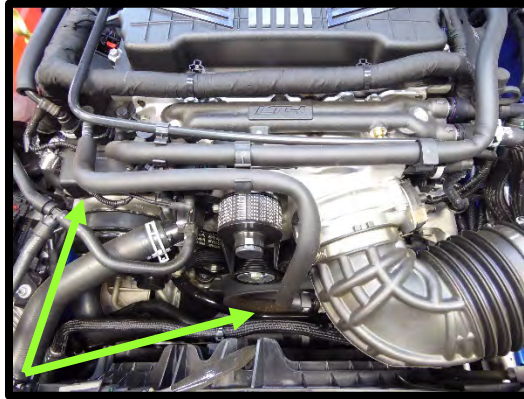

6. Using a 5/16" nut driver, remove the 2 clamps securing the air tube between throttle body and air filter box. Lift and remove away from engine.
7. Disconnect the MAF electrical connector from MAF housing. Using a Phillips screw driver, remove the 6 screws securing airbox lid to the lower. Remove this lid. **Note:** Changing the airbox makes the supercharger system non-emissions legal.

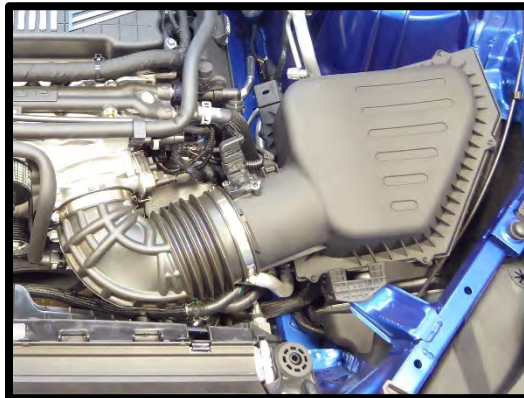

8. Remove the PCV line from the driver side valve cover and passenger side catch can.



9. Remove the EVAP hose from the vent line at the back of the engine to the EVAP solenoid on the driver side front of SC.

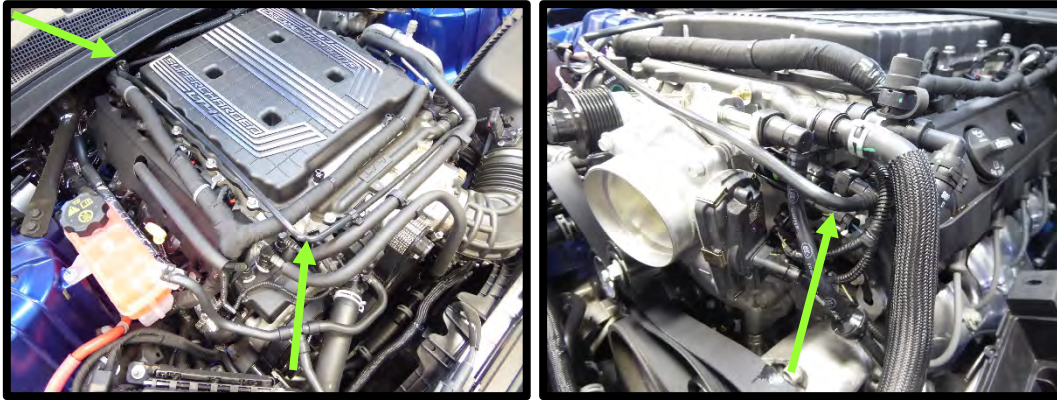

10. Remove brake booster quick connect fitting from SC inlet.

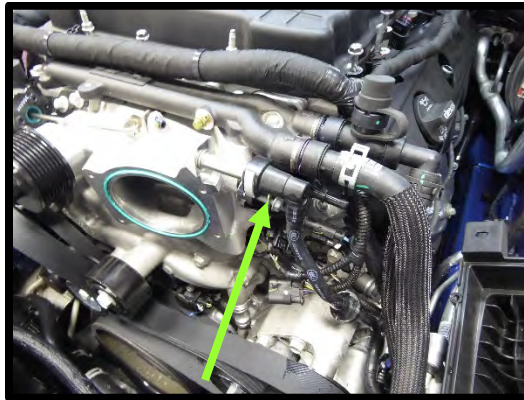

11. Disconnect the electrical connector from the throttle body. Remove the throttle body from the engine by removing the (4) bolts using a 10mm socket.



12. Disconnect EVAP solenoid electrical connector. Using a 10mm socket, remove EVAP solenoid from SC inlet.

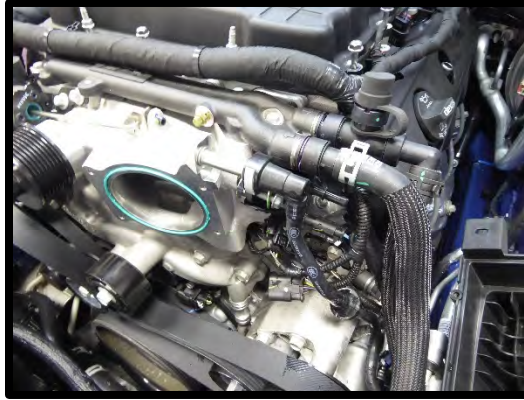

13. Disconnect the 1 bar factory MAP sensor from the inlet.

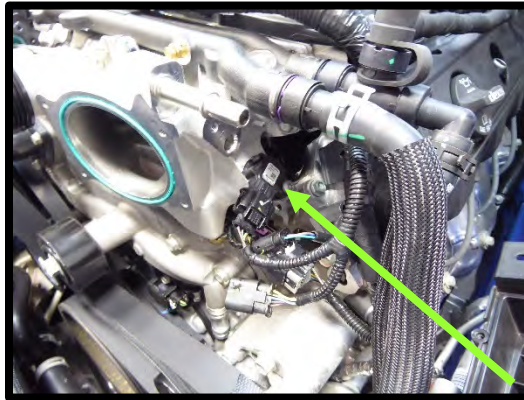

14. Disconnect boost solenoid electrical connector.



15. Install a drain pan under the driver side of engine. Remove the (2) intercooler inlet/outlet fittings from the factory IC water distribution block.

16. Using a 15mm socket or tensioner, release tension from spring loaded tensioner and remove the SC belt.

17. Using a 10mm socket, remove the (20) bolts securing factory SC lid. Carefully lift up and out of the way.

18. Disconnect the factory post SC MAP sensor from the back of intake manifold, passenger side.

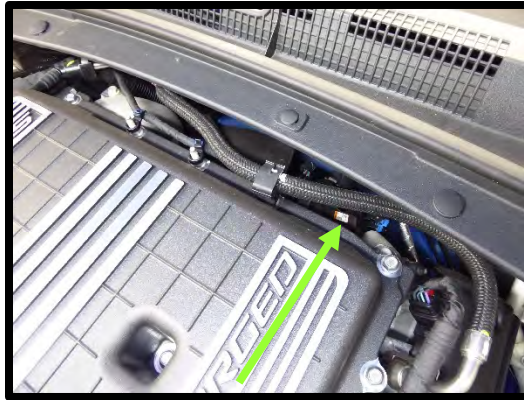

19. Using a 10mm socket, remove the (10) bolts from the supercharger (8 inside, 2 outside).



20. Disconnect the driver side coil harness from the (4) coils and main 10-pin connector at the front of the cylinder head. Swing forward towards airbox to keep out of the way.

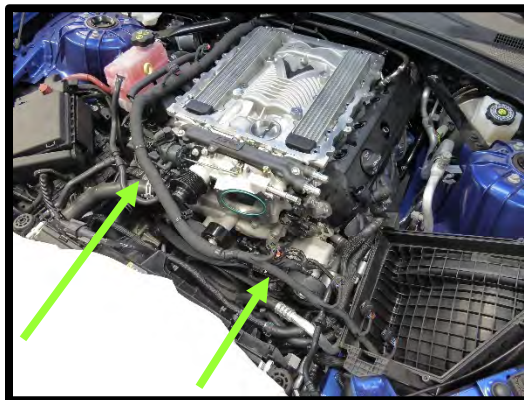

21. Carefully lift the stock supercharger off and away from engine.

22. Remove the bypass solenoid from the stock supercharger using a 13mm socket.



23. Using a T30 Torx socket, remove the factory post SC MAP sensor (3-bar). Install the LT4 3-bar map sensor to the intake manifold. Apply light amount of grease to oring before installing. Secure to manifold using the supplied 6mm x 20mm HHFHCS. Torque to 90 in-lbs.



24. Using a T30 Torx socket, remove the factory pre-SC MAP sensor (1-bar). Install into the boss located at the top of the inlet of the Whipple SC. Apply light amount of grease to oring before installing. Secure to manifold using the supplied 6mm x 20mm HHFHCS. Torque to 90 in-lbs.



25. Remove the sound dampening material from the valley of the block, this will not be reused.



26. Clean the intake manifold surface using carb cleaner or other like chemicals. Cover intake ports with masking tape or duct tape.
27. **HIGHLY RECOMMENDED.** Remove the stock spark plugs & replace with the NGK LZTR6AIX-13 or equivalent. Apply a small amount of anti-seize on the threads and **gap the spark plug to .028"**. If running stock, close gap to .026". Make sure to not damage the electrode during gapping. Torque the spark plug to 11 ft-lbs.
28. Remove the Whipple lid from the supercharger housing for later installation by removing the (18) bolts using a 10mm socket.
29. Remove the intercooler water cross over from the SC assembly by removing the (4) bolts using a 10mm socket.



30. Install the supplied (2) 9.89 to 6 ORB fitting and orings to the inlet casting.

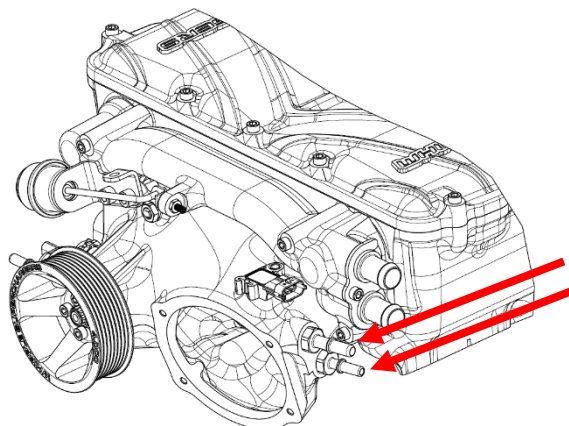

31. Install the factory EVAP solenoid to the inlet casting. Secure using the factory hex head bolt, torque to 96 in-lbs (10mm socket).



32. Remove the factory orings from the intake manifold (8). Clean and inspect orings, replace torn or damaged orings as needed. Install into the new intake manifold. Apply light amount of grease to oring for ease of installation.

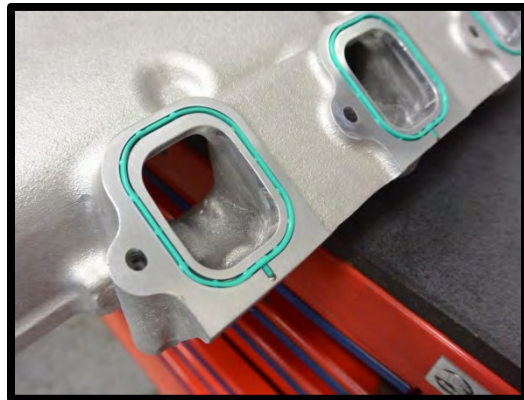

33. Make sure the supercharger is on a flat surface. Remove the oil fill plug using an 8mm allen socket.
- Fill the compressor to the **CENTER** of the sight glass (**6.5 FL/OZ**). Rock compressor back and forth. Then spin the compressor/rotors by the pulley so the oil fills the bearings. **NEVER OVER FILL THE SUPERCHARGER!**
 - Apply light amount of grease to oil fill plug oring, reinstall. Torque to 140 in-lbs.

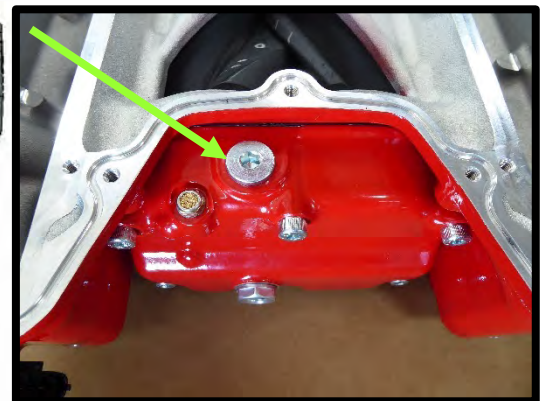
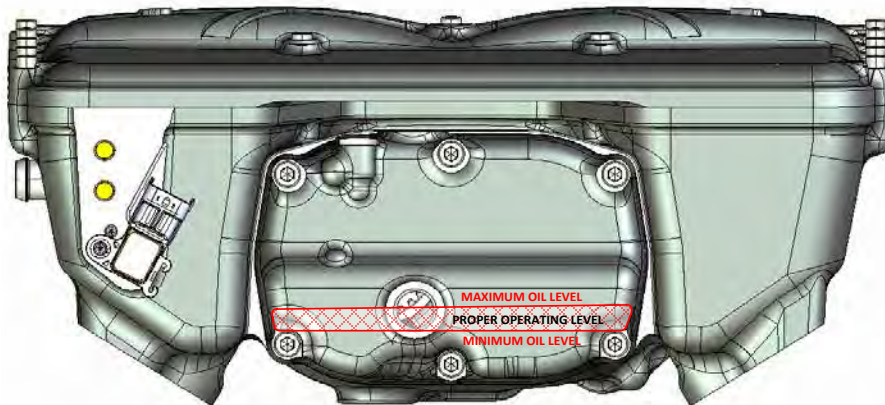

34. Apply light amount of grease/oil to the rubber grommet for the PCV tube on the bottom side of the supercharger housing.

35. Carefully set the supercharger assembly onto manifold. Be cautious of manifold orings while setting on engine. The wiring harness will need to be pulled back to allow SC to drop down.
36. Use the supplied (10) 6mm x 55mm HHFCS and (10) 6mm copper washers to secure SC assembly to motor. Apply light amount of blue Loctite #243 to the threads of each bolt thread, ensure that each bolt is clean and oil free. From the center out, torque the first pass to 70 in-lbs (10mm socket). Follow a second pass to 96 in-lbs.

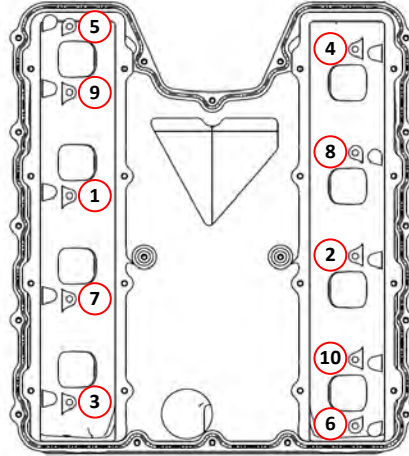

37. Install the supplied 3 bar MAP sensor extension to factory harness.

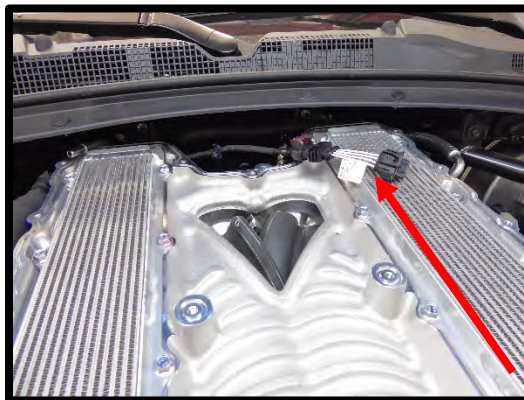

38. Install the original EVAP line fittings to the supplied 3/8" x 25" EVAP hose. Apply light amount of grease to oring to help ease installation.
39. Install the supplied EVAP hose to the factory EVAP fitting near firewall. Install the 90deg fitting to the factory EVAP tube. Route to even cylinder bank side for later installation.



40. Install the supplied driver (odd cylinder) side valve cover vent line fittings into the supplied 3/8" x 53" vent hose, use light amount of grease to oring to help ease of installation.



41. Install the driver side valve cover vent line 45deg fitting in driver side valve cover. Route hose around the back and then around to the even cylinder side of engine for later installation.



42. Install the supplied intercooler cores into the manifold, leave loose for now.



43. Install the supplied (8) 6mm x 10mm HHFCS bolts per core, apply light amount of blue #243 Loctite to threads. Before securing bolts, center the core both front to back and side to side. Torque the (16) bolts in 2 passes (10mm socket), first pass 70 in-lbs and second pass, 85 in-lbs.

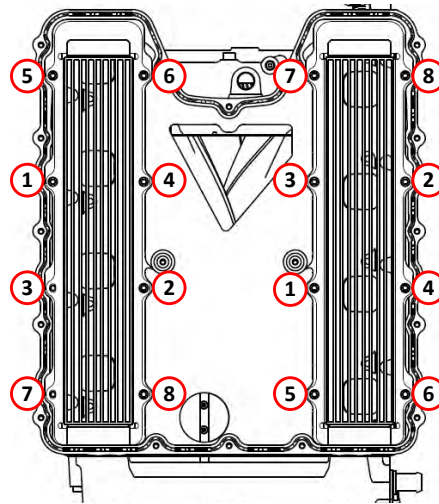
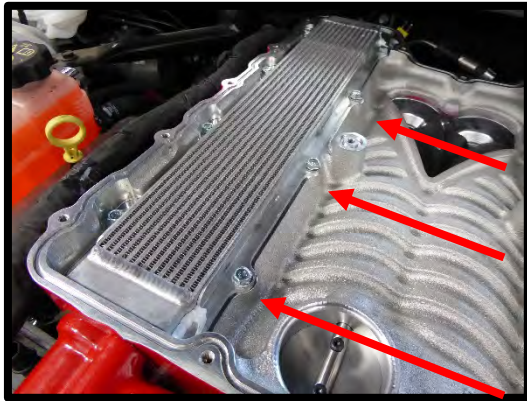

44. Apply light amount of grease to the intercooler cross-over fitting orings (8 orings). Install the (4) IC fittings into the intercooler cross-over.

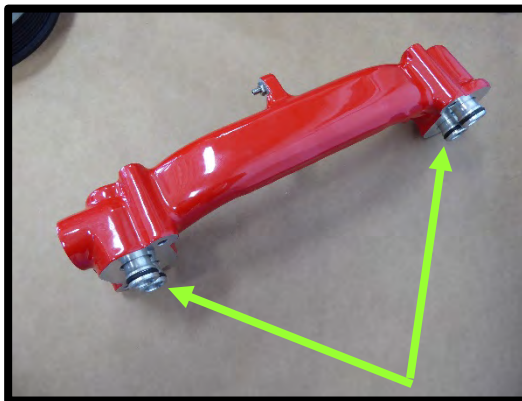

45. Install the (2) orings on the manifold to intercooler cross-over surface on the front of the manifold. Use light amount of grease to help secure oring in place.



46. Carefully install the intercooler cross-over to the manifold by pushing the (4) fittings and cross-over into the intercooler cores. Orings must have grease to fit properly. Use the supplied (2) 6mm x 65mm HHFCS (top), (1) 6mm x 55mm HHFCS (driver side lower) and (1) 6mm x 45mm HHFCS (passenger side lower) bolts. Torque in 2 passes (10mm socket), first pass 65 in-lbs, second pass 75 in-lbs.



47. Install the supplied (2) black intercooler cross-over inlet/outlet fittings and mounting fork to cross-over. Apply light amount of grease to orings for proper installation. Use the supplied (1) 6mm x 10mm HHFCS to secure mounting fork. Torque in 2 passes (10mm socket), first pass 70 in-lbs, second pass 85 in-lbs.

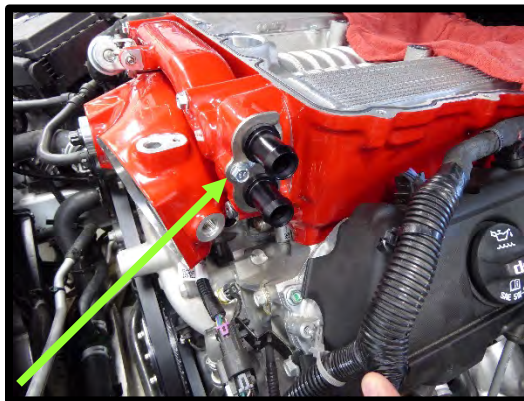

48. Install the supplied (3) orings in the upper manifold. Install the top perimeter oring along with the (2) orings around the bolt bosses. Apply light amount of grease to help hold oring in place.

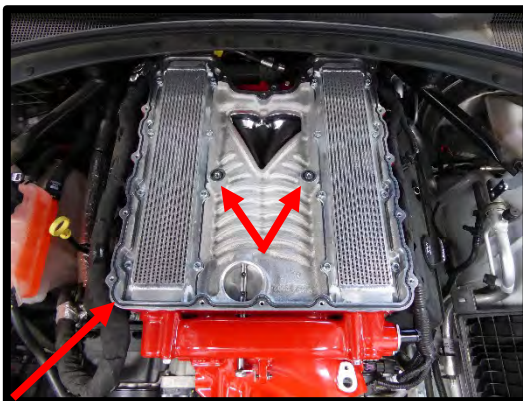

49. Install (2) of the (13) supplied 6mm x 30mm HHFCS in the back 2 bolt holes. Install lid to the manifold by sliding under the cowling. Secure lid to manifold using the (13) 6mm x 30mm HHFS on the perimeter then the (5) 6mm x 40mm HHFCS on the inside. Torque in 2 passes (10mm socket), first pass to 75 in-lbs and second pass, 96 in-lbs.



50. Install the bypass actuator to the cross-over using the (2) 8mm x 12mm BHCS. The bypass holes are slotted, therefore before securing bypass, slide the bypass towards centerline to pre-load the actuator arm. Once pre-load is set, torque bypass bolts to 15 ft-lbs (5mm allen socket).



51. Install the bypass reference hose from the bypass nipple to the barb fitting on the intake manifold. Secure both ends with supplied clamps.

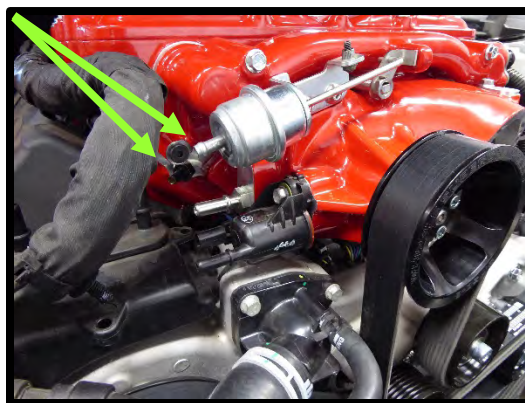

52. Connect the 3/8" x 45" EVAP hose previously routed (straight fitting) to the EVAP solenoid.

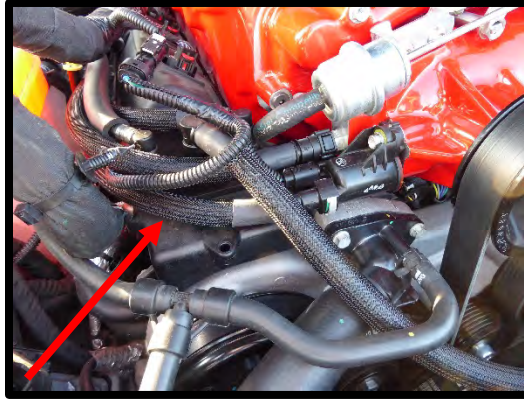

53. Reconnect factory breather line on even cylinder side valve cover to factory catch can outer fitting.

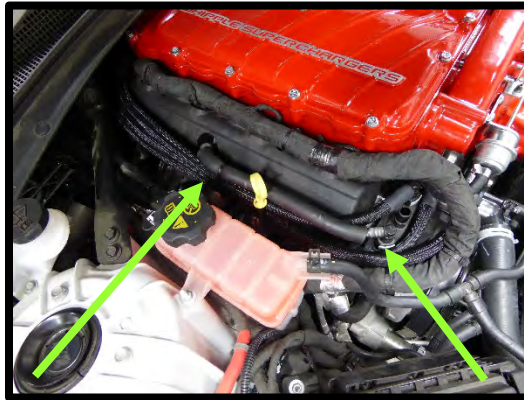

54. Connect the previously routed 3/8" x 53" vent line from driver side valve cover to the inner fitting on catch can.



55. Secure the EVAP and driver side vent line to each other with zip-ties along passenger side valve cover, between the dipstick and passenger side vent line.

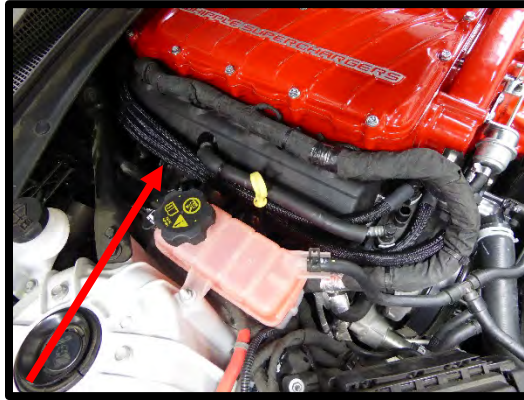

56. Using the supplied #16 Adel clamps, secure wiring harness up over the SC inlet for a clean installation.



57. Install the factory boost solenoid using a zip-tye to secure to vent hose. Connect factory electrical connector, secure away from belt line.



58. Install the supercharger pulley with the supplied (4) 6mm x 12mm SHCS. Torque to 130 in-lbs.

59. Using a breaker bar with 15mm socket, rotate the spring-loaded tensioner counter clockwise to its max open position. Route the supplied supercharger belt as shown in diagram. Use the sliding idler to remove all slack from the belt. Torque idler pulley to 22 ft-lbs and release tensioner. Tensioner must always be set at full to $\frac{3}{4}$ open with a new belt. Failure to set this correctly may result in belt failure.

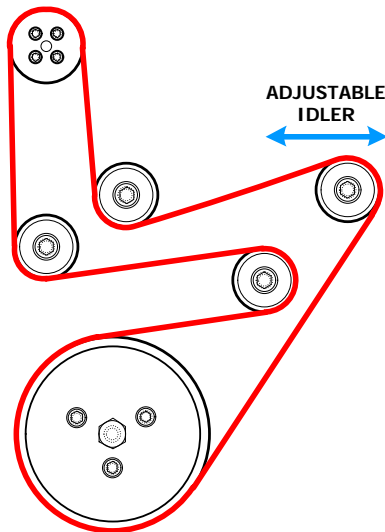

60. Verify that the factory thermostat housing vent line hose clamp is not facing the supercharger belt, if so, rotate out of the way.

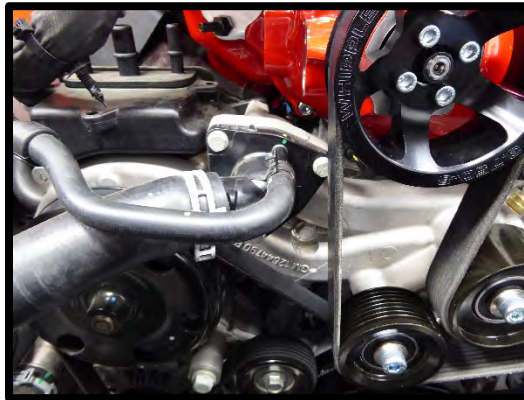

61. Install the throttle body adapter and throttle body to inlet using the supplied gaskets on both sides of the adapter. Use the supplied (4) 6mm x 45mm HHFCS bolts to secure. Torque to 96 in-lbs (10 mm socket). Reconnect factory TB electrical connection. **NOTE:** Stock adapter is 90mm ID, Whipple offers a 102mm for high perf applications and larger TB's.

62. Install the supplied brake booster hose with the 90deg 9.89mm quick connect fitting (3/8" x 15" hose) to the brake booster check valve fitting, route to top 9.89mm to 6 ORB fitting previously installed in inlet.

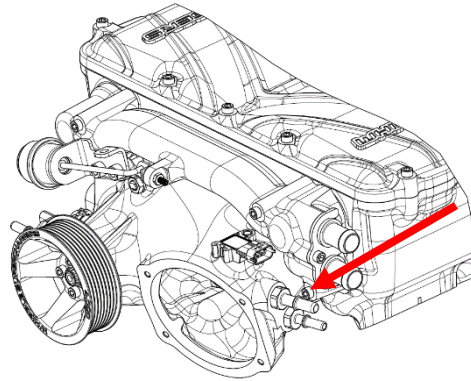
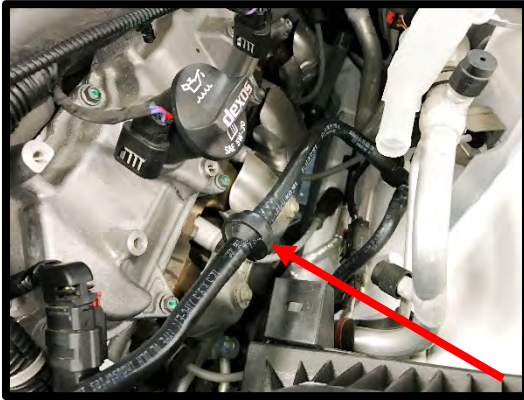

63. Secure the stock IC lines as they were run stock.



64. Secure intercooler lines using zip-tie where necessary for a clean installation.
65. Reinstall stock air filter element into factory location. **NOTE:** Changes to airbox require custom tuning.
66. Install the stock rubber 90deg inlet tube using the stock hose clamps to throttle body and airbox. Install factory airbox lid, secure using factory fasteners.



67. Install the supplied 9.89mm to 3/8" barb fitting to the supplied 90deg inlet tube.

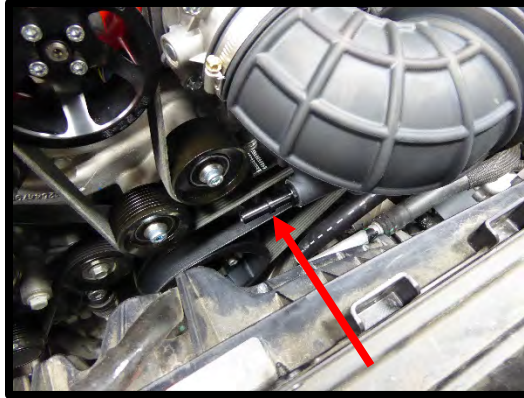

68. Install the 90deg quick connect fitting previously removed from catch can to inlet vent line to the supplied 3/8" x 15" hose. Install straight fitting to the inlet fitting and the 90deg to the catch can. Route line under thermostat housing vent line to secure away from belt.



69. Refill the Engine coolant. Verify that your coolant drain is closed, and use a filter/strainer to pour the recycled coolant/water mixture that you drained from the radiator. If necessary top off with a **GM approved engine coolant**. Whipple also recommends running 2 bottles of Redline Water Wetter which can be found at most automotive parts stores. **⚠ WARNING!! NEVER USE TAP WATER, THIS WILL CAUSE CORROSION IN THE SYSTEM.** Start engine to completely fill system.
70. Attach the negative cable to the battery and tighten using an 8mm wrench.
71. **(Complete kits)** Install the supplied 50-state legal sticker (when applicable) to the hood as the factory emissions sticker. Use light amount of acetone to clean surface before installing.

72. ZL1 applications, the inner hood structure must be notched to clear the SC housing. Follow the included drawing to notch. For a clean installation, use the plastic beading material around the opening.

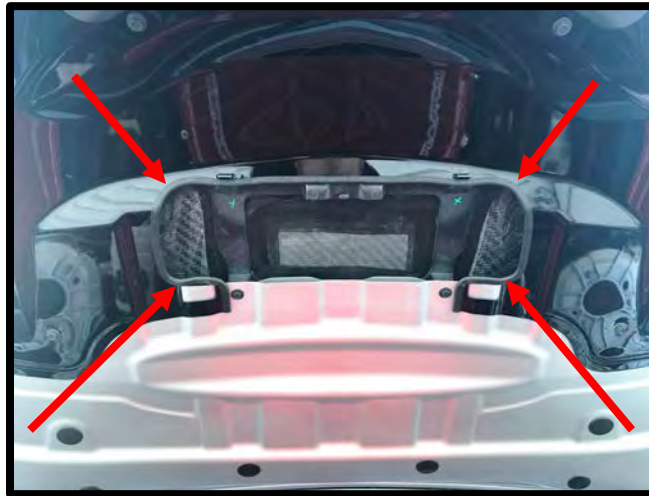

73. Attach the funnel and fill at the factory bleed with a 50/50 mixture of coolant and distilled water until the funnel is half full. Whipple recommends Zerex G-05 to match the stock color. The Whipple IC system is compatible with all common types of antifreeze, it is customer preference. **Note:** Whipple also recommends 1 bottle of Red Line Water Wetter or equivalent. Never use tap water, this will cause corrosion and destroy the system.
74. Turn the ignition to the ON position and listen for the pumps electric motor to cycle. Air bubbles will begin to purge from the system as the coolant level drops. Add coolant to the funnel as necessary. Note: Do NOT let the coolant level in the funnel run empty as this may introduce air into the system.
75. To build more pressure in the intercooler system, try squeezing the intercooler hoses while the pump is cycling. Building pressure in the system will help purge the trapped air from the intercooler system.
76. Cycle the ignition OFF and wait a few seconds for the pump to stop.
77. Cycle the ignition to the ON position again and repeat until the sound of the electric pump is continuous without any pulsation. Hold the start button down for 10 seconds for diagnostic mode, this will run the pump constant for help filling. *NOTE: During water pump start-up, it is normal for a slight pulsation to occur. Once the pump has reached its maximum cycle speed, no pulsations should be present.*
78. Periodically inspect the water pump flow after a few drive cycles and re-fill the intercooler system as necessary.
79. Several drive cycles may be required to completely purge the air from the intercooler system. During a drive cycle, the intercooler system will build up pressure as the supercharger temperature increases. Any residual air trapped in the system will gradually bleed out of the surge tank when the cap is removed. Use a rag when removing in case there is excess pressure. **Do not go WOT or dyno test until the system is properly relieved of air. Note: The pump will cavitate when there's air, this is a sign that it needs to be bled more.**
80. Before driving, make sure that you have 91 or higher octane fuel in the system. Not ½ tank of 87 and ½ tank of 91, all 91 or better fuel in the system. Whipple does not recommend octane booster to bring lower octane to 91.
81. Do not use aftermarket air filter box or duct with the supplied Whipple calibration. The Whipple calibration is designed to work with the Whipple cold air intake system and nothing else. Changes to the air inlet system will require a custom tune which Whipple does not provide.

82. Test drive vehicle for the first few miles under normal driving conditions. Listen for any noises, vibrations, engine misfire or anything that does not seem normal. The supercharger does have a slight whining noise under boost conditions, which is normal. If you chose the aftermarket throttle body, idle may take a few minutes to learn.
83. Re-check the radiator and intercooler reservoir coolant level regularly over the first 1,000 miles, top off level as needed.
84. Inspect belt system and readjust. It's common for the belt to stretch after first heat cycle and may require adjustment.
85. After the initial test drive, go through the belt tensioner process again. On the next test drive, gradually work the vehicle to wide open throttle runs. Listen for any engine detonation (pinging). If engine detonation is present, let up on the throttle immediately. Most detonation causes are low octane gasoline still in the tank.
86. If you have questions about your vehicles performance, please check with your installation facility or call Whipple Superchargers at 559.442.1261, Monday through Friday from 8am to 5:00pm, pacific time or email questions to tech@whipplesuperchargers.com.

⚠ WARNING!! Verify the bypass actuator is working properly. To monitor, look at the bypass arm when the motor is not running. Start engine and verify that the actuator arm has opened. This arm will be extended when the engine is above 2" of vacuum (boost) and will be open when there is more than 3" of engine vacuum.

There is a great deal of misinformation about the function of supercharger bypass systems. The supercharger is a positive-displacement pump; that is, so long as it is rotating, it is always pumping air. During low demand or high vacuum operation (i.e. idle, deceleration, and light throttle cruise), the pumping action is undesirable as it creates unwanted heat and noise. The bypass circuit, when open, prevents any pressure buildup across the supercharger and allows air to circulate through the rotors, allowing the supercharger to "idle" freely during these conditions. This results in reduced noise, and by reducing heat buildup in the intake, significantly improves street and strip performance. As throttle demand increases, the bypass circuit is closed, resulting in full performance and strip performance. As throttle demand increases, the bypass circuit is closed, resulting in full performance from the supercharger. The bypass circuit is never used to limit or control boost during full-throttle operation and defeating or altering the bypass function will not result in improved performance in any condition, and will result in poor drivability and possible supercharger damage.

INSTALLATION NOTES

MAINTENANCE AND SERVICE

Be sure to follow the maintenance and service recommendations below to optimize the life and performance of your Whipple-supercharged vehicle.

For best performance and continued reliability, it is essential to adhere to the following guidelines:

1. Use only premium grade fuel (**91-octane or higher**). RON+MON/2. Higher octane is always a benefit for power and safety.
2. Always listen for any sign of spark knock or pinging. If present, discontinue use immediately and contact Whipple.
3. Do not operate the vehicle at large throttle opening if the MIL lamp is on steadily. This indicates an electronic engine control malfunction: reduce throttle opening and consult your vehicle dealer.
4. Check the supercharger oil level at every engine oil change. Add Whipple SC oil to the supercharger if required. Do not overfill the supercharger rear gear case.
5. Change the oil in the supercharger every 100,000 miles. Use Whipple SC oil or Ford #XL-4 only.

!! CAUTION !!

Severe damage to the compressor will occur if you overfill the supercharger rear gear case.

6. Do not operate the vehicle at large throttle opening if the MIL lamp is on steadily. This indicates an electronic engine control malfunction: reduce throttle opening and consult your vehicle dealer.
7. Inspect and clean your high-flow air filter element every **7,500** miles.
8. Inspect and replace spark plugs every **20,000** miles. **Only run specified plugs.**
9. Follow your factory service intervals for oil changes and other typical maintenance items. Factory oil is always recommended. Using other oils is customer preference.
10. Check the supercharger/accessory drive belt. Adjust or replace as required

!! CAUTION !!

Any modification to your vehicle's new computer program may cause serious damage to the engine and/or drive train. The PCM is locked to the VIN, never let anyone, including dealerships install updates to the PCM. Modifications to the PCM will lock power to stock power levels.

CONGRATULATIONS

Your new Whipple Supercharger is engineered to significantly increase your engines power across a broad range of RPM's. It is Whipple's goal to improve your driving experience for many miles and years to come.

Whipple Superchargers operate as an air pump and contain internal rotors that are driven by the engine's crankshaft and serpentine belts. The supercharger compresses outside air and channels it into the engine's intake ports. Because of their design, superchargers may generate some additional noise over the standard, normally aspirated induction system.

At idle, you may hear a medium-pitch rattle from the supercharger main housing. This will diminish at about 400-500 rpm above idle.

You may also experience a muffled high-pitched whine during acceleration. This is caused by the pumping action of the supercharger compressing air and only occurs during boost conditions. It is inaudible during part-throttle acceleration.

These are normal noises associated with any supercharger and have no effect on supercharger performance or engine durability.

Your supercharger is warranted by Whipple Superchargers, please see your terms and conditions on the back of your invoice for more information in regards to the limited warranty. NOTE: Whipple Superchargers will not authorize any warranty repair work or supercharger replacement for normal noise.

IMPORTANT INFORMATION

DYNO INSTRUCTIONS

When testing on a chassis dyno. 6th gear is 1:1 which will show the highest torque value on inertia based dyno's but will run into the factory speed limiter, therefore 4th gear is ideal for testing.

BOOST LEVELS

All Whipple kits are shipped with boost levels that Whipple feels achieves maximum power while maintaining reliability with stock engines (@ sea level). Additional pulley's are available for lower and higher boost levels, the supplied calibration (complete kits) for the original pulley or larger (lower boost). Higher boost levels must run higher octane levels such as 104, 110, 116, VP Octanium, Torco, etc. or be custom tuned. One can always lower boost with no cal changes required.

EXHAUST

Cat-back exhaust systems help reduce heat and minimize exhaust back pressure. They do not affect the calibration and are always a good idea for added safety and performance. Long tube headers and/or high flow cats require custom calibrations and are not supported by Whipple. While they make more power, they greatly affect the tuning and therefore this should be custom tuned by a reputable tuner.

AIR FUEL RATIO

Air fuel ratio is the measurement of the amount of air and fuel being burned during the combustion process. In order for you to monitor the air fuel ratio, you must have an 18mm bung welded into the exhaust or use OBD data logger to monitor the factory wide bands. The ideal placement is pre-catalytic converter as the catalytic converter can give false readings. While in some cases, it may not be possible to measure air fuel pre-cat, one must verify that post-cat that the motor is running at stoich at idle and should technically show .20 to .50 leaner air fuel ratio.

The Whipple supplied calibration is tuned for WOT 12.00:1 considering 91 octane fuel with 10% Ethanol measured before the cats. Post cat readings may show .25 to .50 leaner. Whipple maintains Catalytic saver mode which richens the target air fuel to maintain cat life. During this, the air fuel may lower up to one full point to maintain temps when cats overheat.

FUEL SYSTEM

The Whipple fuel system (FLOW) needs no additional changes for power levels supplied by Whipple. Any smaller pulley changes, custom calibration, custom engines may require fuel system changes.

FUEL OCTANE

Never run a fuel octane that is below 91 octane, $(RON+MON)/2$ and never run fuel with more volume than 10% Ethanol. It is recommended, when available, to run 92-94 octane. Never mix mid-level (below 91) with 91+, this is very dangerous and can cause severe engine damage. Do not attempt to increase octane ratings with generic octane boosters, these are very hard on spark plugs and many brands do very little to the actual octane rating (1 point is .1 octane). For emergency situations and racing applications, the best octane booster found to date is VP Octanium M additive (#1 choice) and NOS "Off-road" formula. Some other brands are hard on spark plugs so constant use will require increased spark plug maintenance.

ENGINE COOLANT

Whipple recommends running a 50/50 mix of distilled water and coolant (race applications should run 70/30). The engine coolant temp should run between 180-190deg F under normal driving conditions. The fans are turned on at an earlier temp to promote cooler operating temps. We also recommend 1-2 bottles of Red Line Water Wetter coolant additive. This will reduce air bubble insulation, which increases overall engine temp.

FUEL LEVEL

Never operate at WOT when the vehicle fuel levels are below a 1/8 tank. Low fuel levels could cause the fuel pump to cavitate and you'll have fuel flow spikes resulting in lean conditions and consequently detonation.